

A3HG Series High Pressure Variable Displacement Piston Pumps

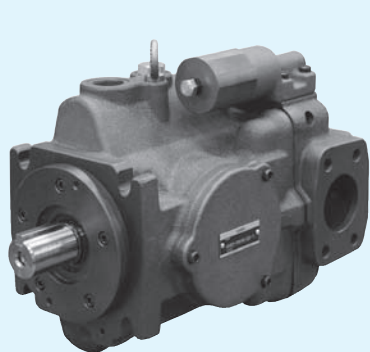

A3HG71

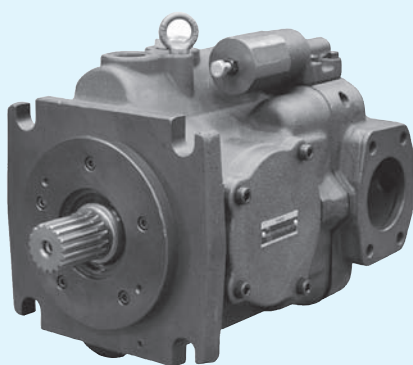

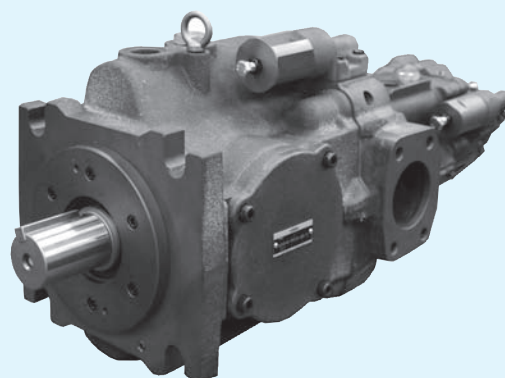

A3HG100



A3HG Through Drive

“A3HG” Series High Pressure Variable Displacement Piston Pumps

Pump Type	Graphic Symbol	Geometric Displacement cm ³ /rev								Maximum Operating Pressure MPa	Page			
		1	2	5	10	20	50	100	200			300		
 Series High Pressure Variable Displacement Piston Pumps					A3HG16									
					A3HG37									
						A3HG56								
						A3HG71						35	156	
						A3HG100								
						A3HG145								
						A3HG180								

★ Four control types are available such as pressure compensator type. Refer to page 157.

Hydraulic Fluids

Hydraulic Fluids

Use clean petroleum base oils equivalent to ISO VG-32 or 46. The recommended viscosity range is from 20 to 400 mm²/s and temperature range is from 0 to 60 C°, both of which have to be satisfied for the use of the above hydraulic oils.

Control of Contamination

Due caution must be paid to maintaining control over contamination of the operating oil which can otherwise lead to breakdowns and shorten the life of the unit. Please maintain the degree of contamination within NAS Grade 9.

The suction port must be equipped with at least a 100 μm (150 mesh) reservoir type filter and the return line must have a line filter of under 10 μm.

Instructions

Mounting

When installing the pump the filling port should be positioned upwards.

Alignment of Shaft

Employ a flexible coupling whenever possible, and avoid any stress from bending or thrust. Maximum permissible misalignment is less than 0.1 mm TIR and maximum permissible misangular is less than 0.2.

Suction Pressure

Permissible suction pressure at suction port of the pump is between -16.7 and +50 kPa. In case of the speed is over 1800 r/min, adjust the pressure 0 to +50 kPa.

For piping to the suction port, use the pipes of the same diameter as that of the specified pipe flange to be used. Make sure that the height of the pump suction port is within one metre from the oil level in the reservoir.

Hints on Piping

When using steel pipes for the suction or discharge ports, excessive load from the piping to the pump generates excessive noise.

Whenever there is fear of excessive load, please use rubber hoses.

Suction Piping

In case the pump is installed above the oil level, the suction piping and suction line filter should be located lower than the pump position to prevent air in the suction line.

Pilot Piping

Install Pilot piping according to the chart.

[Recommended Pilot Piping Size]

Port /Flange Code	Fitting Size	Inside Dia. of Pipe
E1, E2	M14×1.5	6 mm or more
U1	1/2-20UNF	
U2	G 1/4	
J1	R 1/4	

Drain Piping

Install drain piping according to the chart and ensure that pressure within the pump housing should be maintained at a normal pressure of less than 0.1 MPa and surge pressure of less than 0.5 MPa.

Length of piping should be less than 1 m, and the pipe end should be submerged in oil.

[Recommended Drain Piping Size]

Model	Port /Flange Code	Fitting		Inside Dia. of Pipe
		Size	Inside Dia.	
A3HG16 A3HG37	E1, E2	M22×1.5	12 mm or more	12 mm or more
	U1	7/8-14UNF		
	U2	G 1/2		
A3HG56 A3HG180	J1	R 1/2	16 mm or more	19 mm or more
	E1, E2	M27×2		
	U1	1 1/16-12UNF		
	U2	G 3/4		
	J1	R 3/4		

Safety Valve

When delivery line is blocked suddenly, surge pressure is occurred so a safety valve should be set in the circuit to eliminate any damage on equipment and piping.

Bleeding Air

It may be necessary to bleed air from pump case and outlet line to remove causes of vibration.

Starting

Before first starting, fill pump case with clean operating oil via the fill port.

In order to avoid air blockage when first starting, adjust the control valves so that the discharged oil from the pump is returned direct to the tank or the actuator moves in a free load.

[Volume of Pre-fill Oil Required]

Model	Volume cm ³	Model	Volume cm ³
A3HG16	400	A3HG100	1600
A3HG37	850	A3HG145	2350
A3HG56	1050	A3HG180	3300
A3HG71	1480	—	—

■ Setting Discharge Pressure and Delivery

At the time of shipment, the unit has been preset to maximum delivery and minimum discharge pressure. Adjust the preset delivery and pressure to meet your system requirements.

● Adjustment of Discharge Pressure

Turning the adjustment screw clockwise, increases pressure. For the volume adjusted by each full turn of the adjustment screw, see below Table.

After adjustment, make sure to tighten the lock nut.

[Volume adjusted by each full turn of the pressure adjustment screw]

Model Numbers	Adjustment Volume MPa
A3HG16/A3HG37/A3HG56-01	5.5
A3HG71/A3HG100/A3HG145-01	6.3
A3HG180-01	5.7

● Adjustment of Delivery

Turning the flow adjustment screw clockwise, decreases delivery. For the volume adjusted by each full turn of the adjustment screw, see below Table.

After adjustment, make sure to tighten the lock nut.

[The minimum adjustable flow and adjustable volume of each full turn of the delivery adjustment screw]

Model Numbers	Adjustable volume with each full turn of the adjustment screw cm ³ /rev	Minimum adjustment flow cm ³ /rev
A3HG16	1.4	8
A3HG37	3.3	16
A3HG56	4.2	35
A3HG71	4.9	45
A3HG100	6.2	63
A3HG145	9.4	95
A3HG180	10.3	130

■ Flow Adjustment Screw Protrusion Length “L” vs. Geometric Displacement (reference)

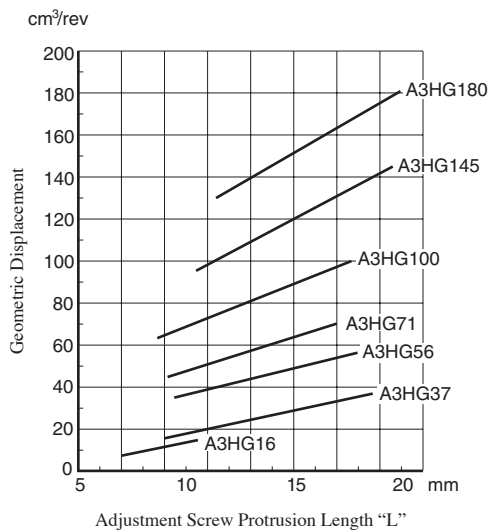
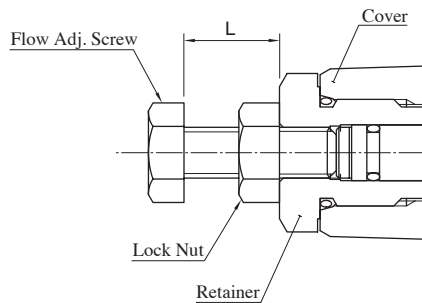

A3HG Series High Pressure Variable Displacement Piston Pumps

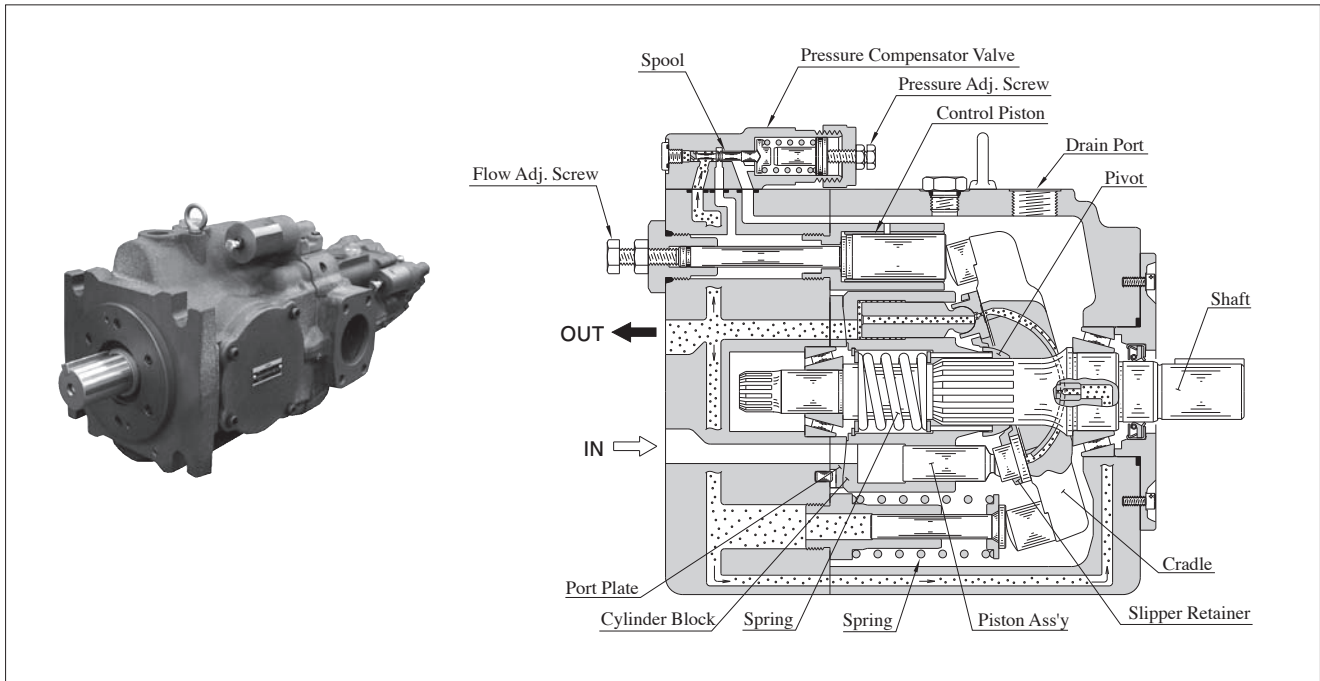

Features

Conforming to International Standards

We have widened the range and now have available pumps not only with JIS mounting but also ISO 3019-2 and ISO 3019-1 variants as standard depending on market needs.

Both Keyed Shaft and Spline Shaft are available as standard design.

Mounting

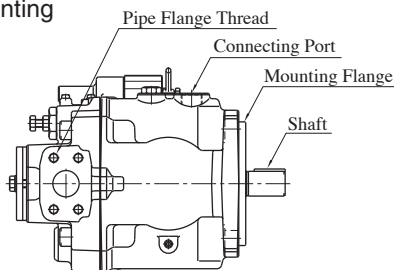

Frange/Port Code	Pipe Flange Thread	Connecting Port	Mounting Flange and Shaft
E1, E2	Metric	Metric	Conforms to ISO 3019-2
U1	Unified	Unified	Conforms to ISO 3019-1
U2	Metric	BSPP	Conforms to ISO 3019-1
J1	Metric	Rc	Conforms to ISO 3019-1

Shaft Extension

Keyed



Spline



High Pressure and wide flow range

Maintaining the high performance of our A3H pumps, the improved A3HG series now offers a nominal pressure of 31.5 MPa. With a wide flow range, varying from 16.3 cm³/rev to 180.7 cm³/rev.

Supporting a wide range of applications as mid-high load capacity pumps.

Through-drive System Adopted as A Standard Feature

The through-drive system adopted as a standard feature allows connecting a pump having the same capacity as the driving pump on the driven side, increasing the maximum flow range. Any pump conforming to international standards can be used on the driven side; replacement in machines can be readily done.

Wide Variety of Control Modes

Four control modes are available to support various functions:

pressure compensator type, pilot pressure control type pressure compensator, constant power control type with external pilot and load sensing type.

Control Type

Control Type	Graphic Symbols	Performance Characteristics	Explanation	Page
“01” Pressure Compensator Type			<ul style="list-style-type: none"> When the system pressure increases and comes close to the preset cut-off pressure, the pump flow decreases automatically while maintaining the set pressure as it is. The output flow and full cut-off pressure can be manually adjusted. 	158
“07” Pilot Pressure Control Type Pressure Compensator			The pump is used in combination with the pilot relief valve or multistage pressure control valve. By controlling the pilot pressure, the full cut-off pressure can be remote-controlled according to your requirements.	177
“09V” Constant Power Control Type With External Pilot			<ul style="list-style-type: none"> This type of control can control the pump input power according to the motor output. When the system pressure increases, the output flow decreases, in correspondence to predetermined shaft input values. This type of control can enable one pump to act as two pumps (low-pressure and large-flow/high-pressure and small-flow). Therefore, the motor capacity can be reduced. This type of control provides the remote control of the full cut-off pressure by connecting a remote control relief valve to the pilot port “PP”. 	184
“14” Load Sensing Type			<ul style="list-style-type: none"> This is an energy-saving type control which maintains the pump flow and load pressure at the absolute minimum necessary level to operate the actuator. This type of control automatically regulates the output flow so that the inlet-outlet differential pressure of the flow control valve at the output side is constant. To do so, the load pressure must be introduced to the load sensing port “L” of the pump through the external piping. This type of control provides the remote control of the full cut-off pressure by connecting a remote control relief valve to the pilot port “PP”. 	191

★ A flow control valve is not included with the pump. Install the valve separately.

Availability of Control Type

Mark “○” in the table below refers to standard model.

Model Numbers	Geometric Displacement cm ³ /rev	Control Type			
		“01”	“07”	“09V”	“14”
A3HG16	16.3	○	○		○
A3HG37	37.1	○	○	○	○
A3HG56	56.3	○	○	○	○
A3HG71	70.7	○	○	○	○
A3HG100	100.5	○	○	○	○
A3HG145	145.2	○	○	○	○
A3HG180	180.7	○	○	○	○

A3HG Series High Pressure Variable Displacement Piston Pumps Pressure Compensator Type

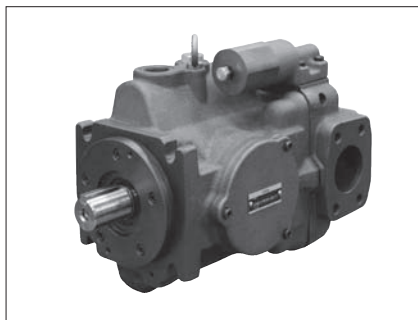

Graphic Symbol

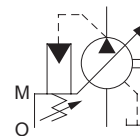

Specifications

Model Numbers	Geometric Displacement cm ³ /rev	Minimum Adjustment Flow cm ³ /rev	Operating Pressure MPa		Shaft Speed Range r/min		Approx. Mass kg			
			Rated ^{★1}	Intermittent	Max. ^{★2}	Min.	Flange Mtg.	Foot Mtg.		
A3HG16- *R01K * - *C-10	16.3	8	31.5	35	3600	600	17	21		
A3HG37- *R01K * - *C-10	37.1	16			2700	600	26.5	35		
A3HG37- *R01K * - *D-10							34			
A3HG56- *R01K * - *C-10	56.3	35			2500	600	34.5	43		
A3HG56- *R01K * - *D-10							32.5	40		
A3HG71- *R01K * -E1D/E2D-10	70.7	45			2300	600	45	71		
A3HG71- *R01K * -U1D/U2D/J1D-10							41.5	49		
A3HG100- *R01KK-E1D/E2D-10	100.5	63			2100	600	56.5	81.5		
A3HG100- *R01KSP * -E1D/E2D-10							56	81		
A3HG100- *R01K * -U1D/U2D/J1D-10							56	83		
A3HG145- *R01KK-E1D/E2D-10	145.2	95			1800	600	68.5	94.5		
A3HG145- *R01KSP * -E1D/E2D-10									68	94
A3HG145- *R01K * -U1D/U2D/J1D-10									68	95.5
A3HG180- *R01KK-E1D/E2D-10	180.7	130			1800	600	88	114		
A3HG180- *R01KSP * -E1D/E2D-10									87.5	113.5
A3HG180- *R01KK-U1D/U2D/J1D-10									87.5	115

★1. Consult Yuken when pump is used over rated pressure because there is a restriction on operating condition.

★2. The maximum shaft speeds shown in the above table are at suction pressure 0 kPa.

Model Number Designation

A3HG16	-F	R	01	K	K	-E1					D	-10	
Series Number	Mounting	Direction of Rotation	Control Type	Pres. Adj. Range MPa	Shaft Extension	Main Pump Mtg. Flange Connecting Port / Pipe Flange Thread Second Pump Mtg.					Number of Pump Mtg. Bolts	Design Number	
A3HG16 (16.3 cm ³ /rev)	F: Flange Mtg. L: Foot Mtg.	(Viewed from Shaft End) R: Clockwise (Normal)	01: Pressure Compensator Type	K: 5 - 35	K: Keyed Shaft SP: Splined Shaft (High torque) SP1: Splined Shaft (Conforms to ISO 3019-1)	Code	Main Pump Mtg. Flange	Connecting Port	Pipe Flange Thread	Second Pump Mtg.	C: 2	D: 4	10
A3HG37 (37.1 cm ³ /rev)													10
A3HG56 (56.3 cm ³ /rev)													10
A3HG71 (70.7 cm ³ /rev)													10
A3HG100 (100.5 cm ³ /rev)													10
A3HG145 (145.2 cm ³ /rev)													10
A3HG180 (180.7 cm ³ /rev)													10

■ Pipe Flange Kits

Pipe flange mouting surface conforms to SAE J 518, 4 bolt split flange.
 Pipe flange kits are not available. Contact us for the details.

Response Characteristics Change in Accordance with Circuits and Operating Conditions.

■ Test Circuit and Conditions

● Circuit

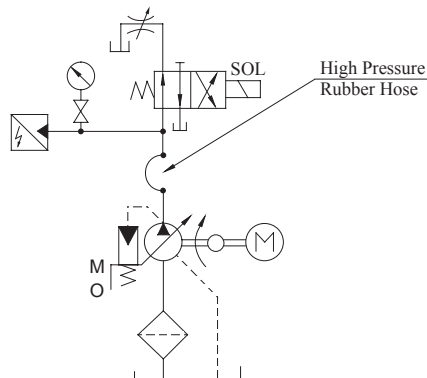

● Size of High Pressure Rubber Hose

Model	High Pressure Rubber Hose
A3HG16	3/4B × 1500 mm
A3HG37/56/71	3/4B × 2000 mm
A3HG100/145	1-1/4B × 2000 mm
A3HG180	1-1/4B × 2500 mm

● Conditions

Drive Speed : 1500 r/min
 Hydraulic Fluid : ISO VG32 Oil
 Oil Temperature: 40°C [Viscosity 32 mm²/s]

■ Result of Measurement

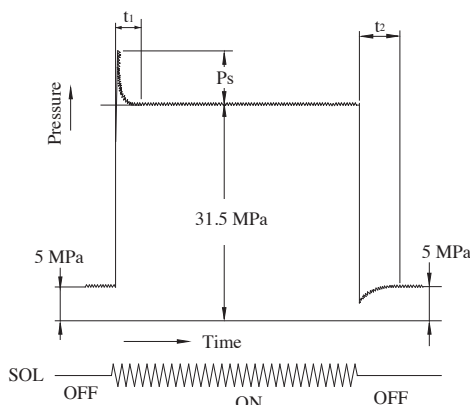

Model	Response Time ms		Overshoot Pressure P_s MPa
	t_1	t_2	
A3HG16	130	140	2.5
A3HG37	95	70	4.0
A3HG56	105	90	7.5
A3HG71	80	125	9.5
A3HG100	85	140	11.0
A3HG145	85	150	12.0
A3HG180	95	230	16.0

Typical Performance Characteristics of Type **A3HG16** at Viscosity 32 mm²/s [ISO VG32 oils, 40°C]

Performance Characteristic Curve

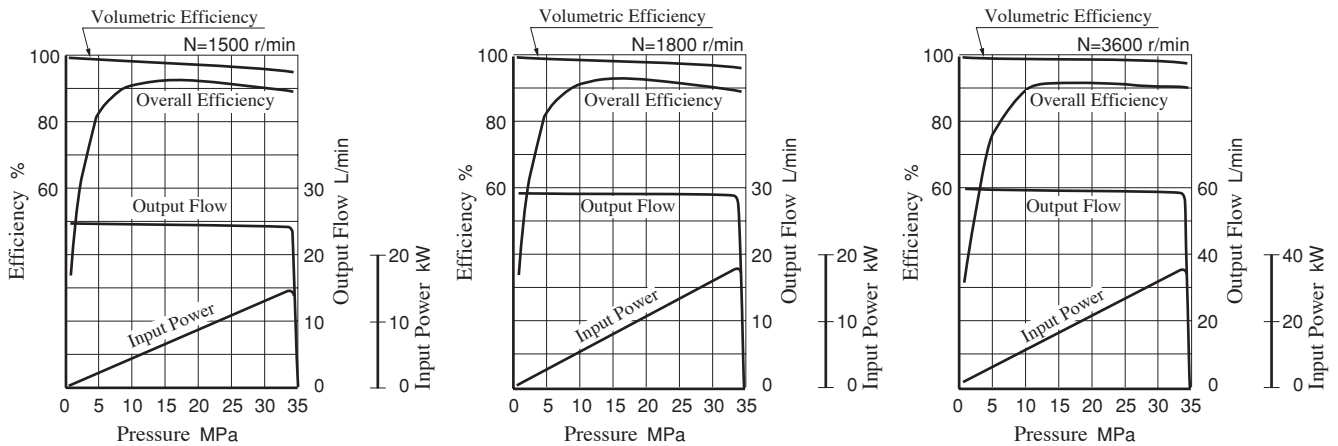

Input Power

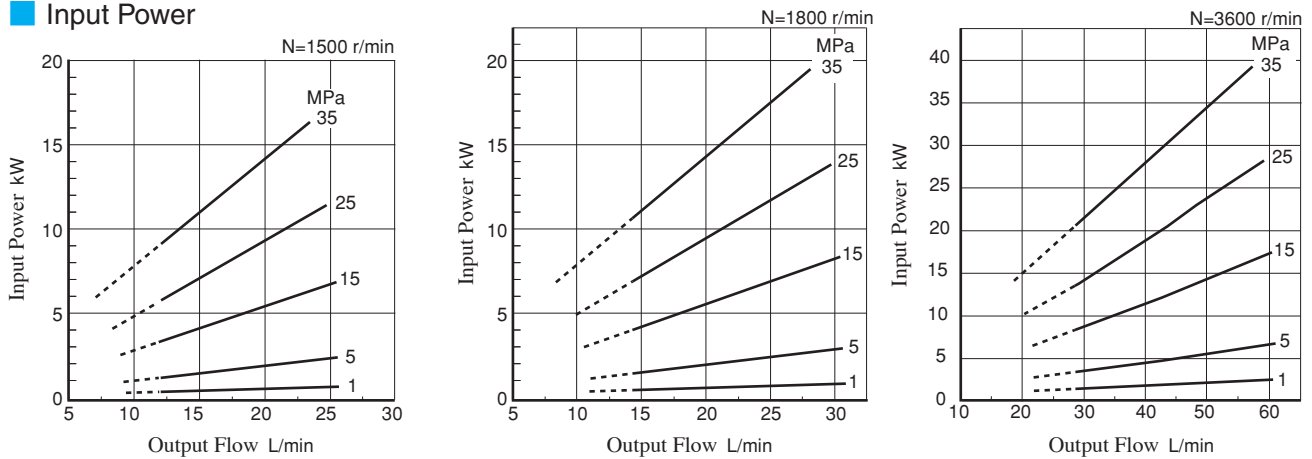

★ The dotted line in the graph indicates less than minimum adjustable flow.

Full Cut-off Power

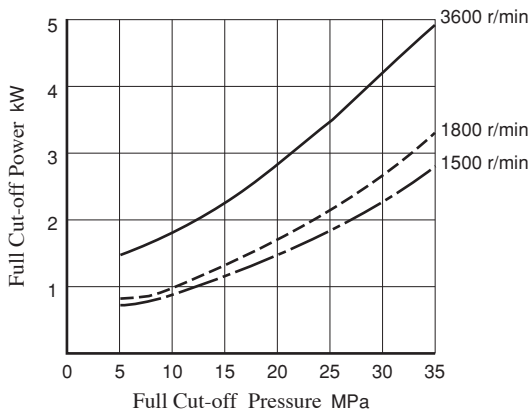

Drain

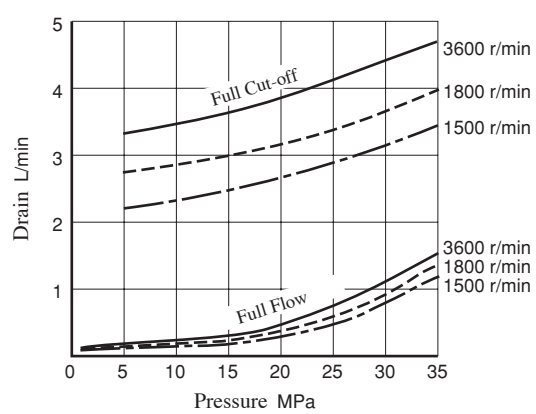

Noise Level [One metre horizontally away from pump head cover]

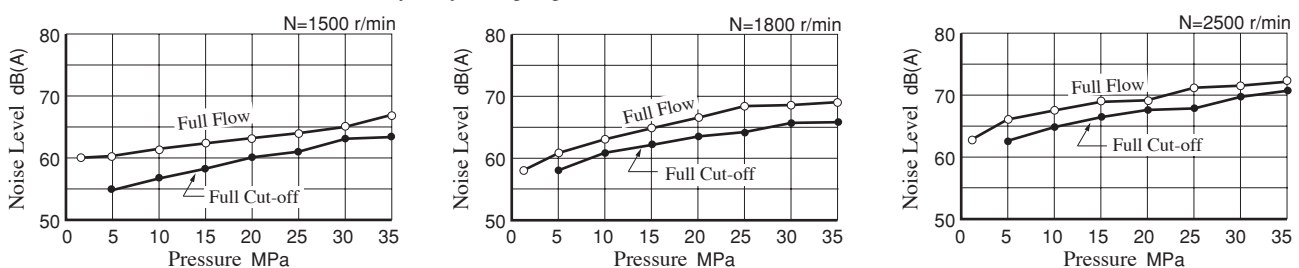

Typical Performance Characteristics of Type **A3HG37** at Viscosity 32 mm²/s [ISO VG32 oils, 40°C]

Performance Characteristic Curve

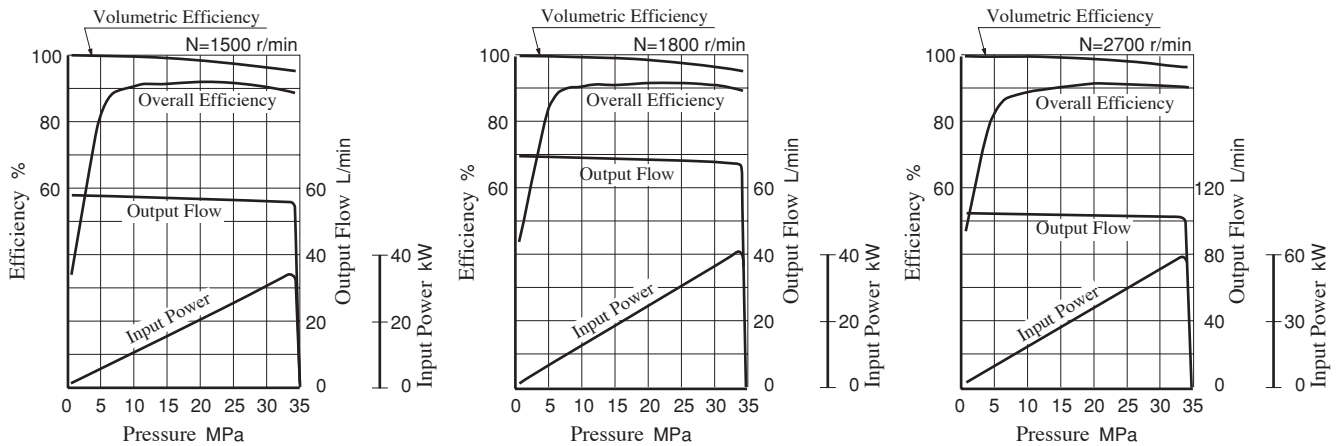

Input Power

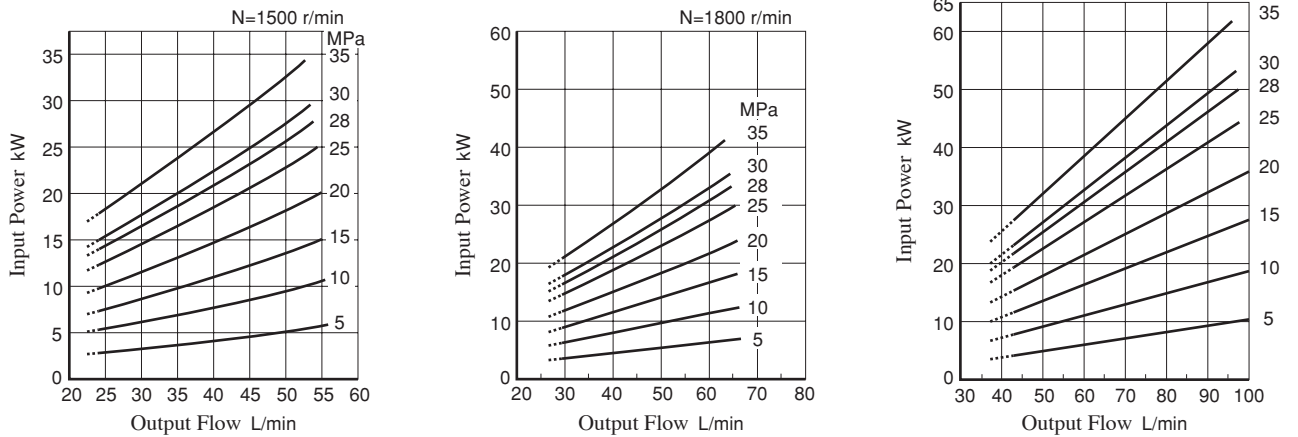

★ The dotted line in the graph indicates less than minimum adjustable flow.

Full Cut-off Power

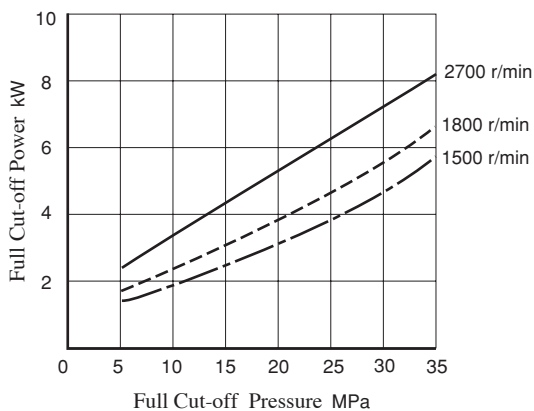

Drain

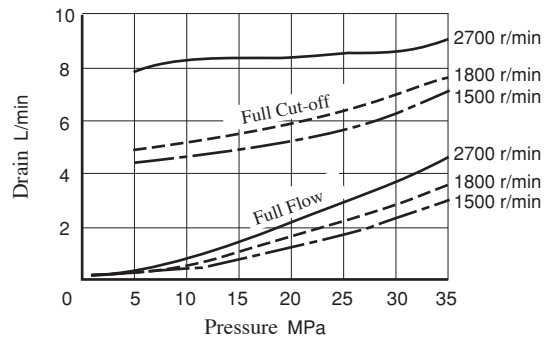

Noise Level [One metre horizontally away from pump head cover]

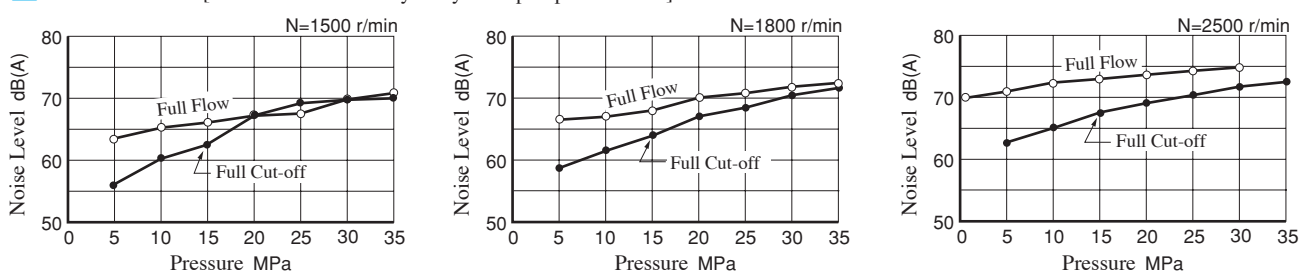

Typical Performance Characteristics of Type **A3HG56** at Viscosity 32 mm²/s [ISO VG32 oils, 40°C]

Performance Characteristic Curve

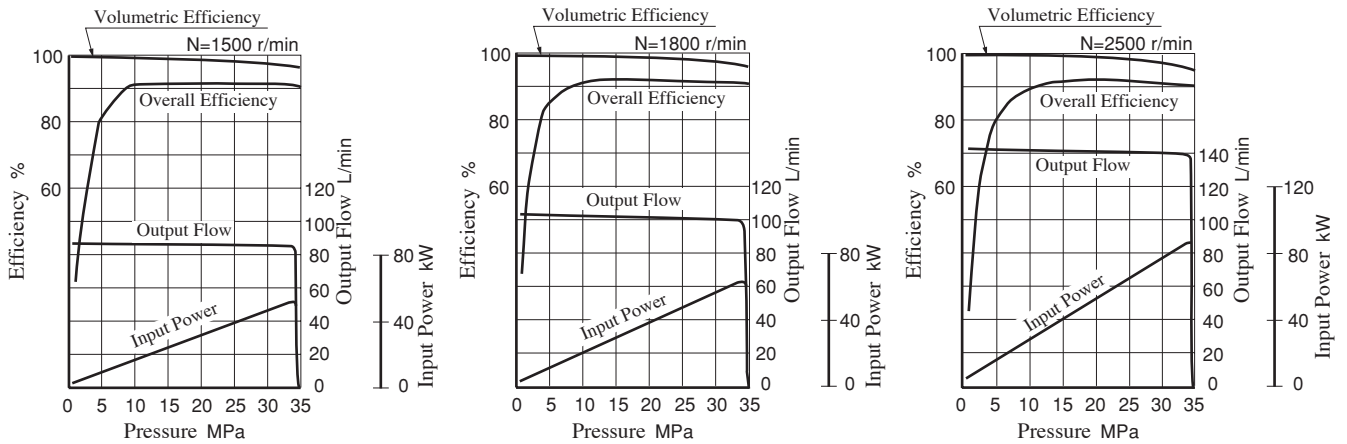

Input Power

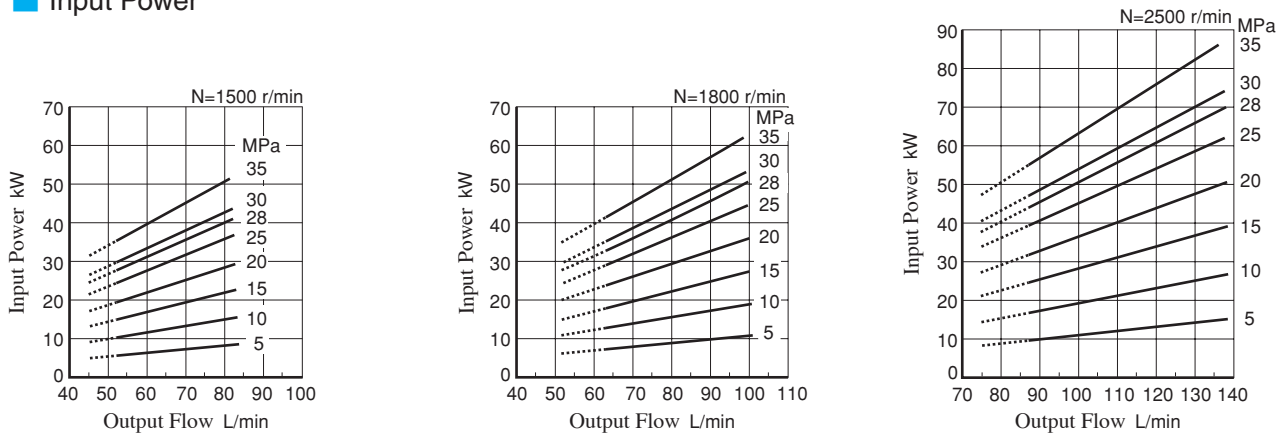

★ The dotted line in the graph indicates less than minimum adjustable flow.

Full Cut-off Power

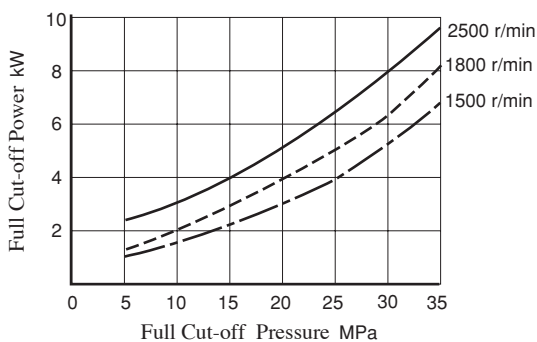

Drain

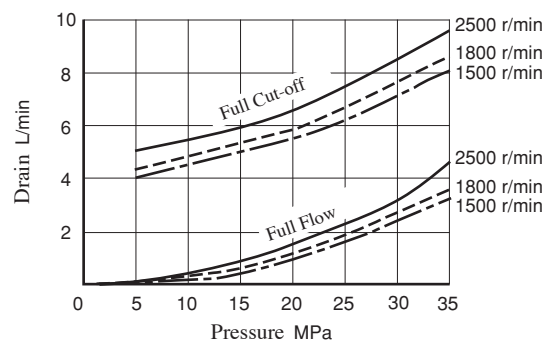

Noise Level [One metre horizontally away from pump head cover]

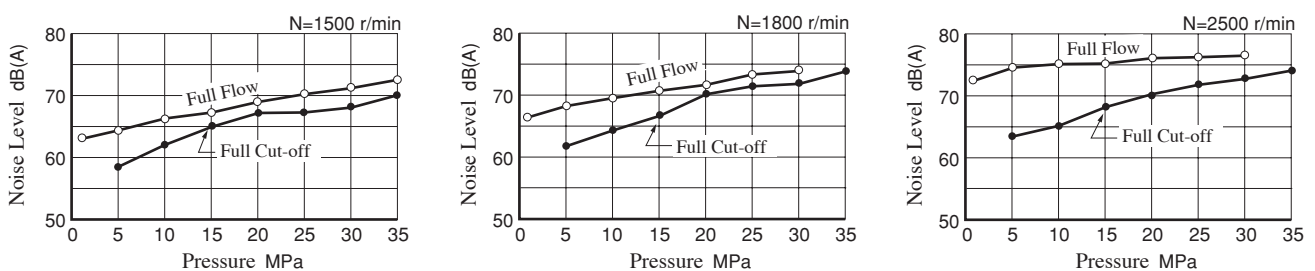

Typical Performance Characteristics of Type **A3HG71** at Viscosity 32 mm²/s [ISO VG32 oils, 40°C]

Performance Characteristic Curve

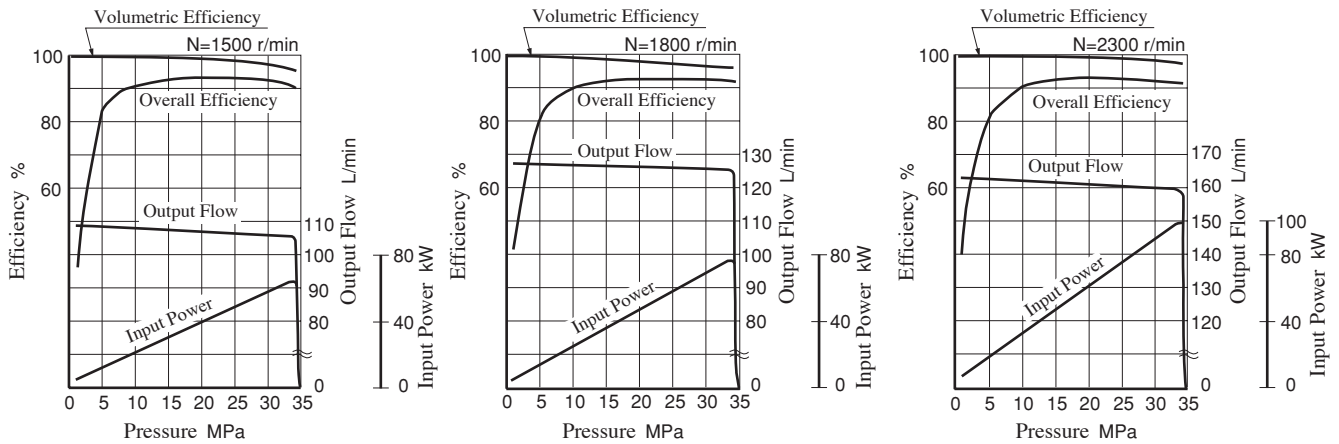

Input Power

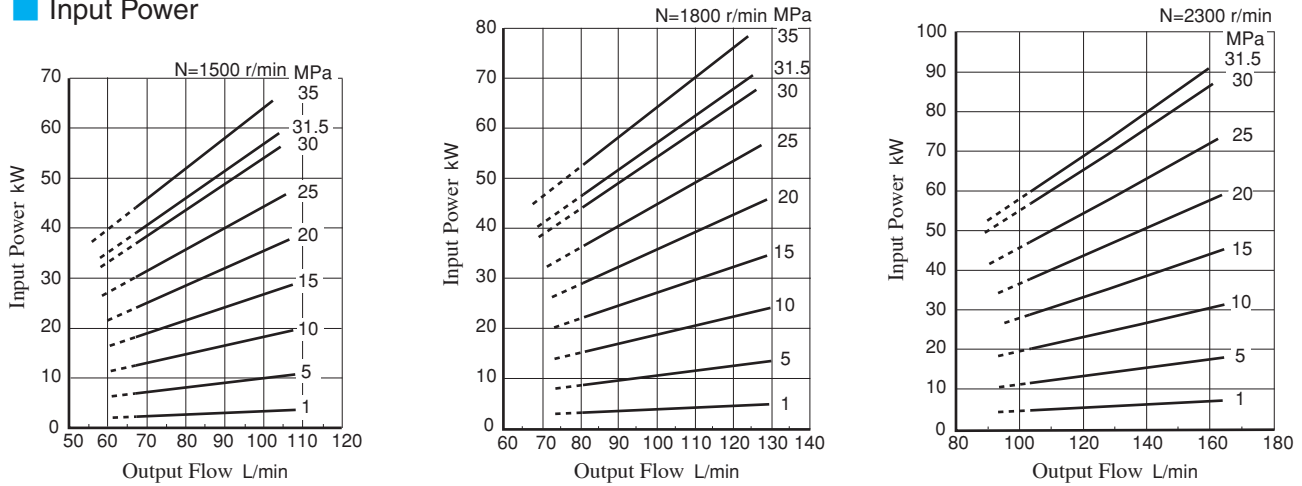

★ The dotted line in the graph indicates less than minimum adjustable flow.

Full Cut-off Power

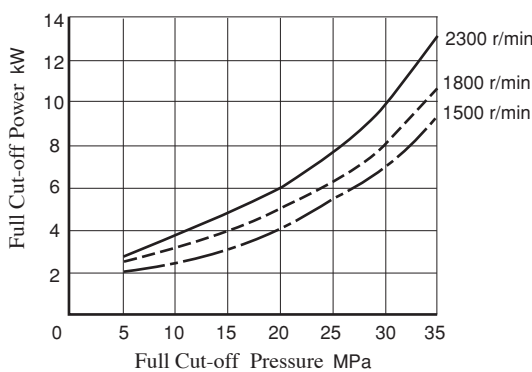

Drain

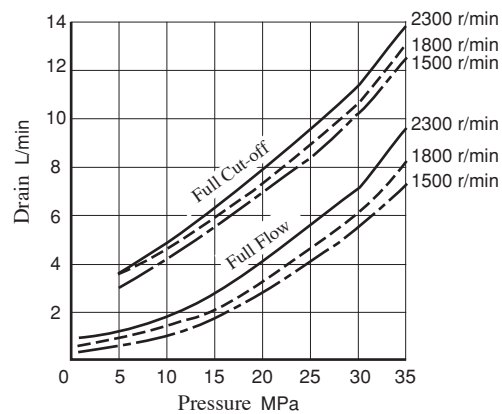

Noise Level [One metre horizontally away from pump head cover]

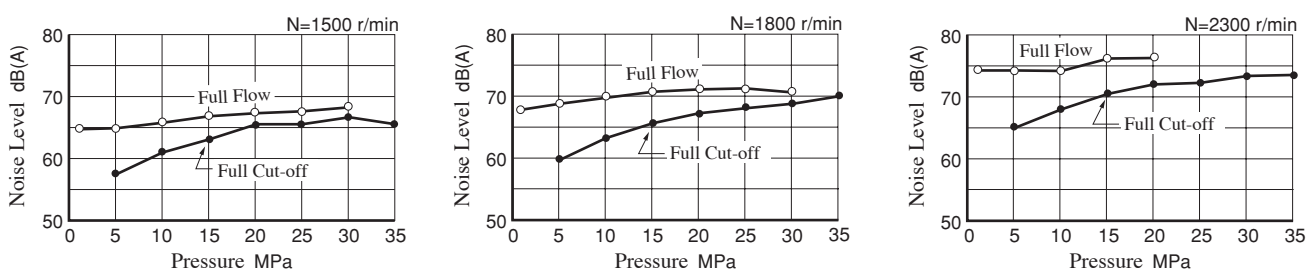

Typical Performance Characteristics of Type **A3HG100** at Viscosity 32 mm²/s [ISO VG32 oils, 40°C]

Performance Characteristic Curve

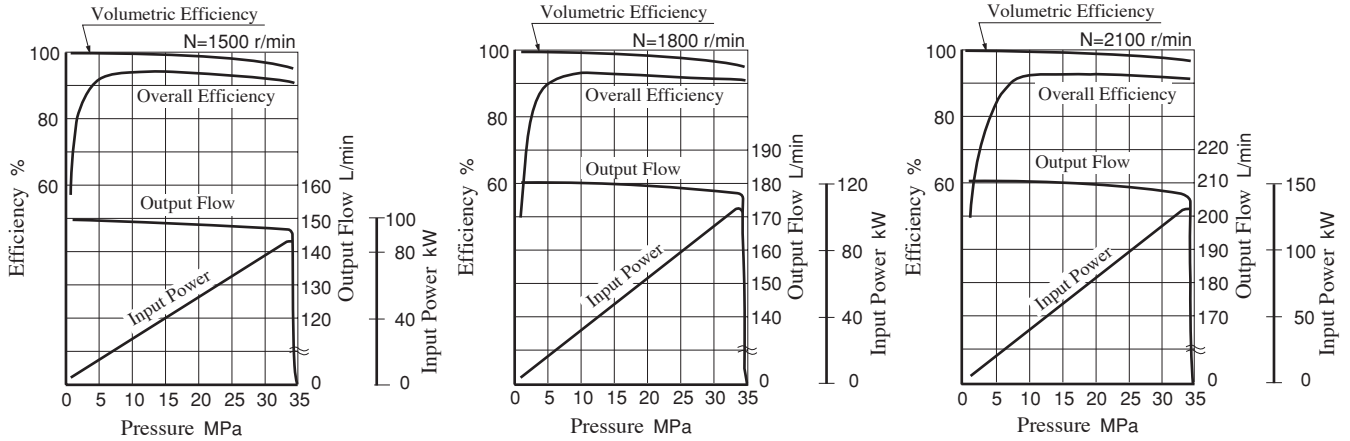

Input Power

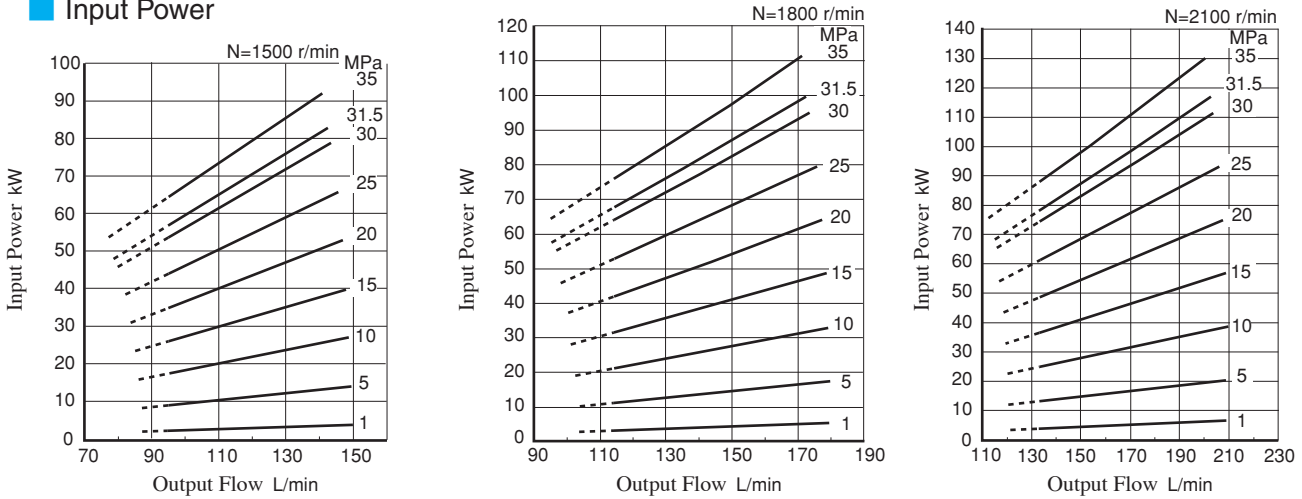

★ The dotted line in the graph indicates less than minimum adjustable flow.

Full Cut-off Power

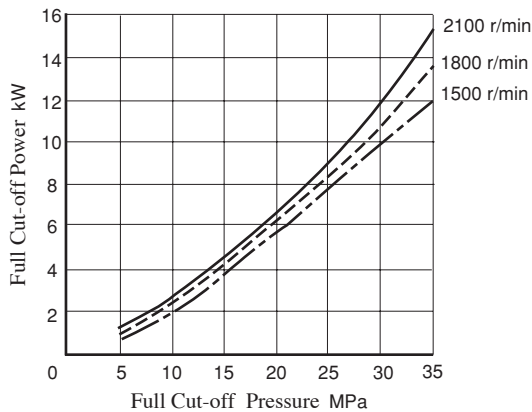

Drain

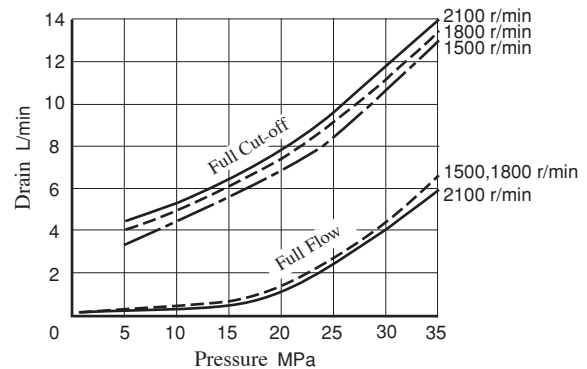

Noise Level [One metre horizontally away from pump head cover]

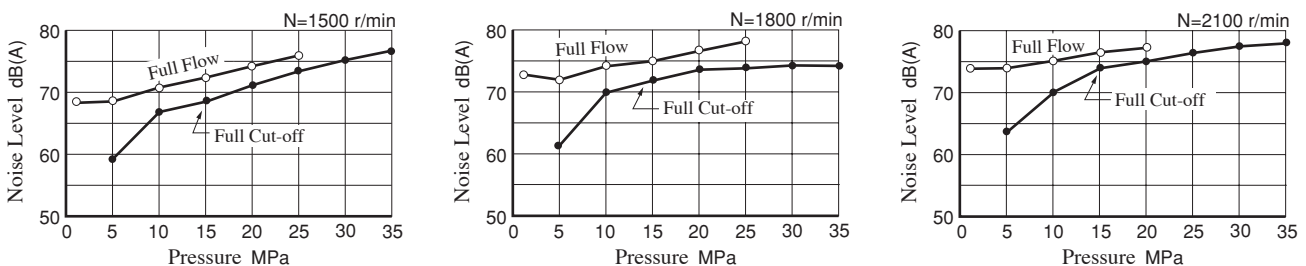

Typical Performance Characteristics of Type **A3HG145** at Viscosity 32 mm²/s [ISO VG32 oils, 40°C]

Performance Characteristic Curve

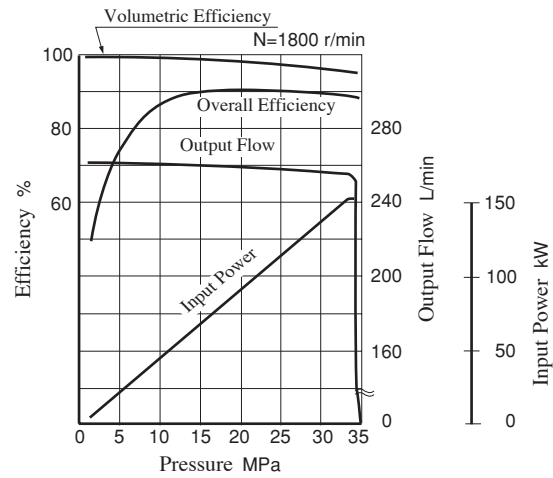
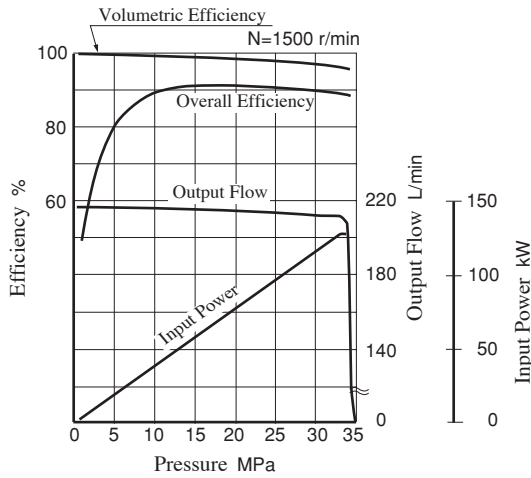

Input Power

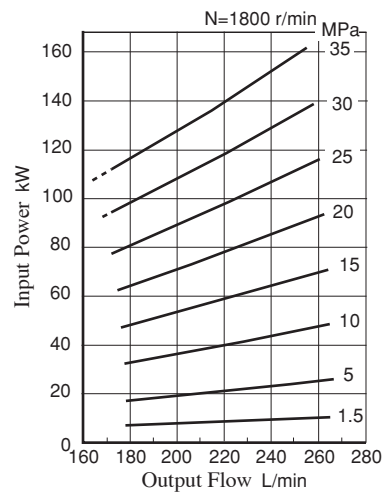
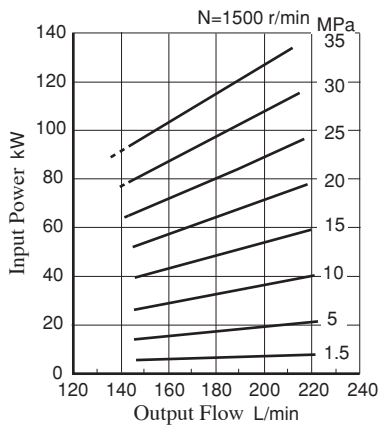

★ The dotted line in the graph indicates less than minimum adjustable flow.

Full Cut-off Power

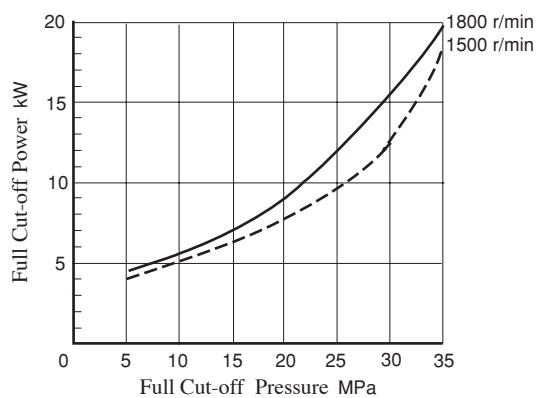

Drain

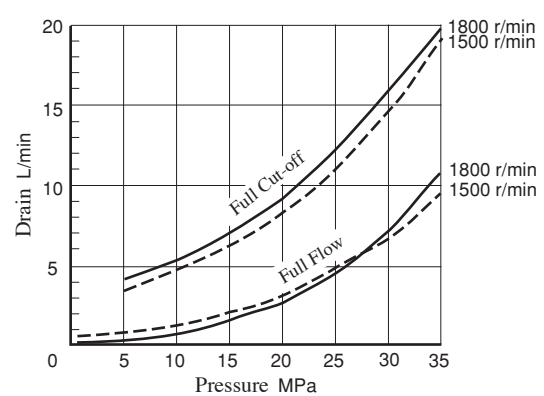

Noise Level [One metre horizontally away from pump head cover]

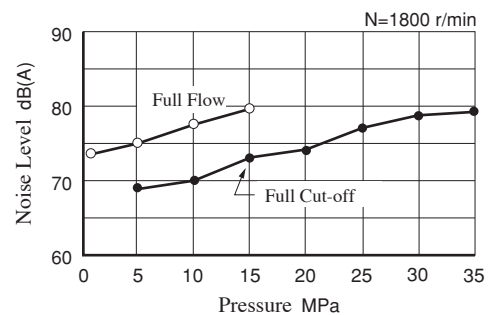
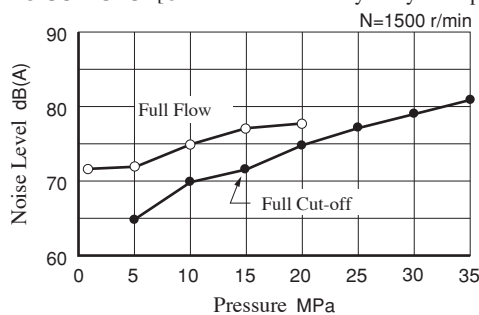

Typical Performance Characteristics of Type **A3HG180** at Viscosity 32 mm²/s [ISO VG32 oils, 40°C]

Performance Characteristic Curve

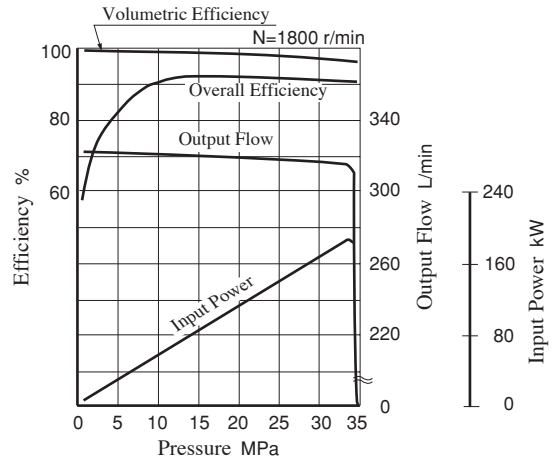
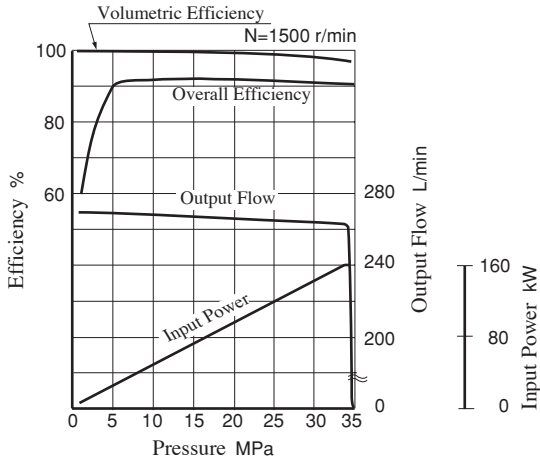

Input Power

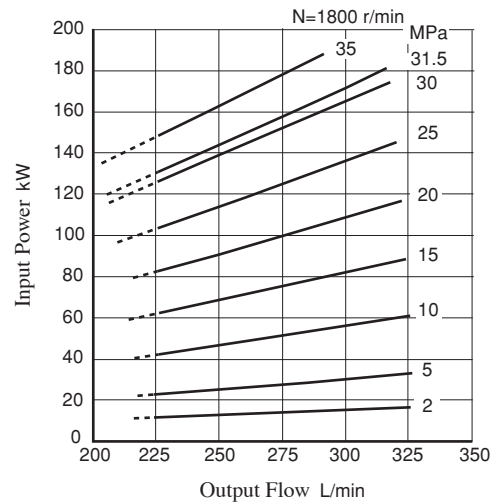
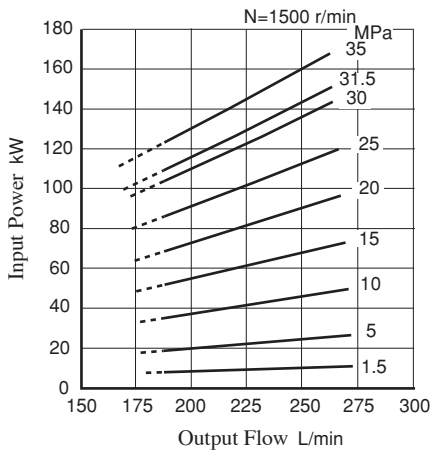

★ The dotted line in the graph indicates less than minimum adjustable flow.

Full Cut-off Power

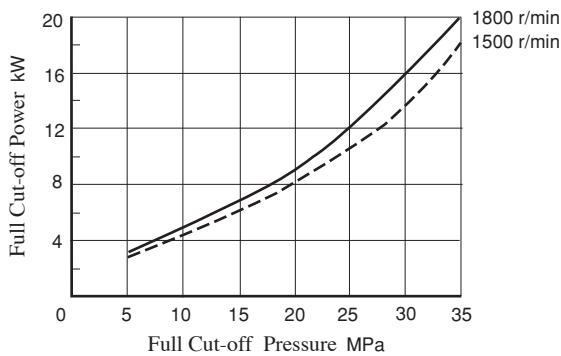

Drain

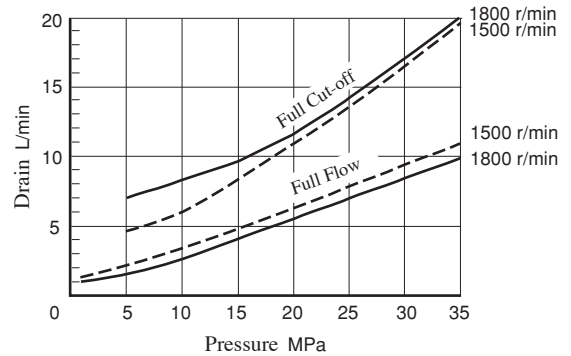

Noise Level [One metre horizontally away from pump head cover]

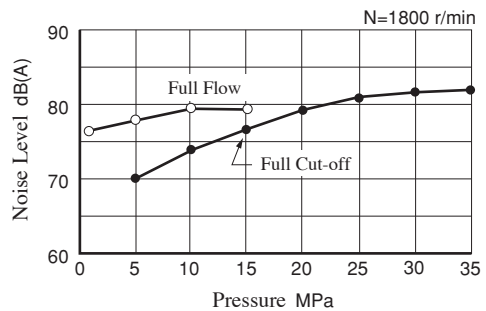
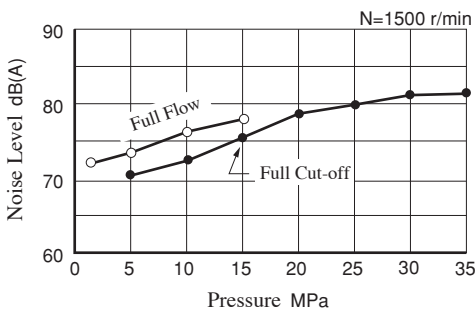

Flange Mtg.:A3HG16-FR01KK-E1C/U1C/U2C/J1C

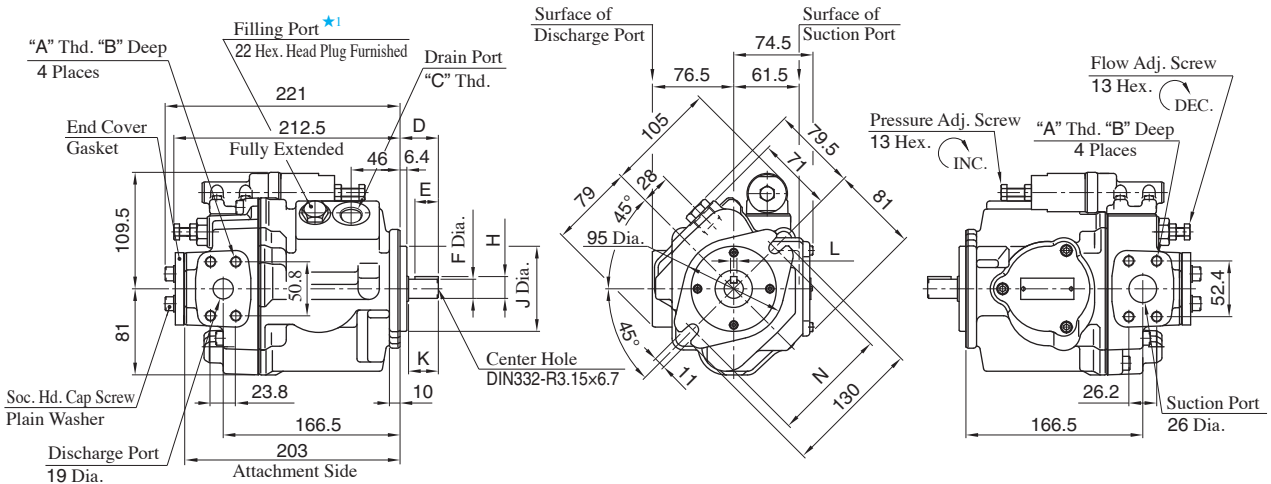

★1. Install the pump so that the "Filling Port" is at the top.

Model Numbers	A	B	C	D	E	F	H	J	K	L	N	Mounting Flange	Connecting Port	Pipe Flange Threads
A3HG16-FR01KK-E1C	M10	19	M22X1.5	36	22	18 ^{+0.008} _{-0.003}	20.5 ^{+0.008} _{-0.133}	80 ⁰ _{-0.046}	28	6 ⁰ _{-0.03}	109	Conforms to ISO 3019-2	Metric	Metric
A3HG16-FR01KK-U1C	3/8-16 UNC	17	G 1/2	41	28	19.05 ⁰ _{-0.03}	21.24 ⁰ _{-0.16}	82.55 ⁰ _{-0.05}	33	4.76 ^{+0.03} ₀	106	Conforms to ISO 3019-1	Unified	Unified
A3HG16-FR01KK-U2C	M10	19	G 1/2	41	28	19.05 ⁰ _{-0.03}	21.24 ⁰ _{-0.16}	82.55 ⁰ _{-0.05}	33	4.76 ^{+0.03} ₀	106	Conforms to ISO 3019-1	BSPP	Metric
A3HG16-FR01KK-J1C	M10	19	G 1/2	41	28	19.05 ⁰ _{-0.03}	21.24 ⁰ _{-0.16}	82.55 ⁰ _{-0.05}	33	4.76 ^{+0.03} ₀	106	Conforms to ISO 3019-1	Rc	Metric

Drain Port

For Port/Flange Code "U1/J1", Adapter and bonded seal are attached. After installing the bonded seal at the drain port tighten the adapter

Detail:A3HG16-FR01KK-E1C

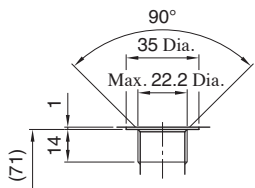

Detail of Drain Port ★2

★2. Drain port conforms to ISO 9974-1, metric threads.

Accessories:A3HG16-FR01KK-U1C

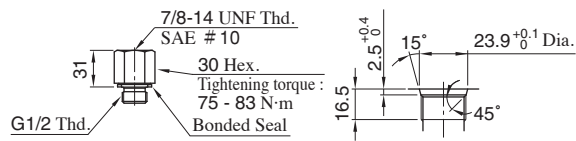

Adapter

Detail of Adapter Port ★3

★3. Adapter port conforms to SAE J 514, O-Ring seals.

Detail:A3HG16-FR01KK-U2C

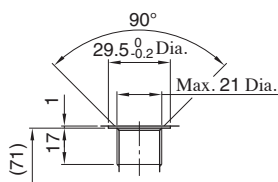

Detail of Drain Port ★4

★4. Drain port conforms to ISO 1179-1, BSPP threads.

Accessories:A3HG16-FR01KK-J1C

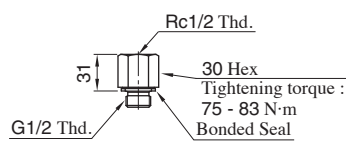

Adapter

Foot Mtg.:A3HG16-LR01KK-E1C/U1C/U2C/J1C

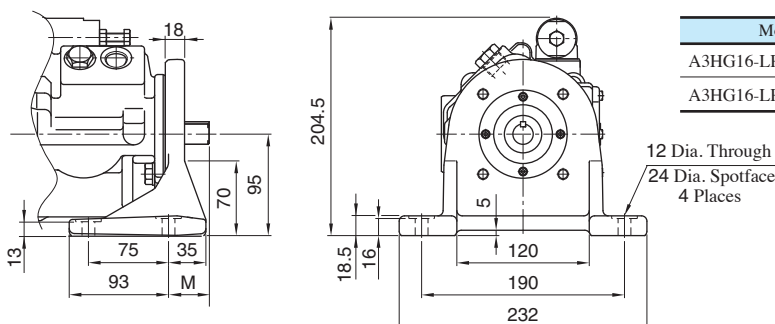

Model Numbers	M
A3HG16-LR01KK-E1C	33
A3HG16-LR01KK-U1C/U2C/J1C	38

● For other dimensions, refer to "Flange Mtg.".

Flange Mtg. Four Bolts:A3HG37-FR01KK-E1D/E2D/U1D/U2D/J1D

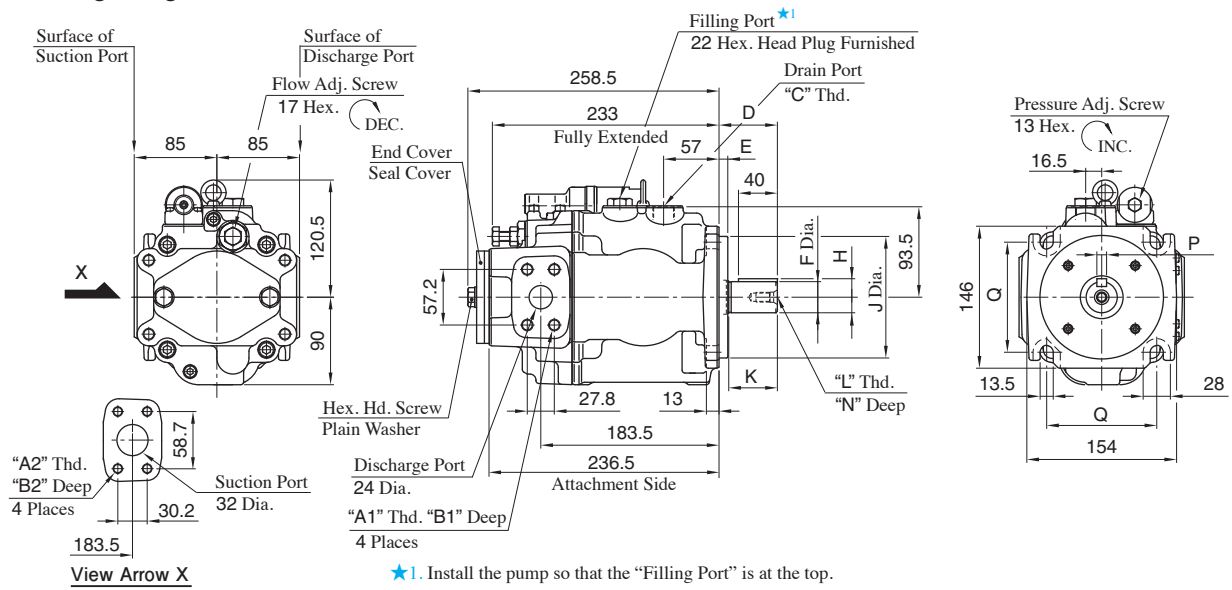

Model Numbers	A1	A2	B1	B2	C	D	E	F	H	J	K	L	N	P	Q	Mounting Flange	Connecting Port	Pipe Flange Threads
A3HG37-FR01KK-E1D/E2D	M12	M10	22	18	M22×1.5	60	9	32 ^{+0.018} _{-0.002}	35 ^{+0.018} _{-0.288}	125 ⁰ _{-0.063}	50	M10	22	10 ⁰ _{-0.036}	113.2	Conforms to ISO 3019-2	Metric	Metric
A3HG37-FR01KK-U1D	7/16-14 UNC		20		G 1/2	56	12.7	31.75 ⁰ _{-0.05}	35.32 ⁰ _{-0.18}	127 ⁰ _{-0.05}	48	5/16-18 UNC	19	7.94 ^{+0.03} ₀	114.5	Conforms to ISO 3019-1	Unified	Unified
A3HG37-FR01KK-U2D	M12	M10	22	18	G 1/2	56	12.7	31.75 ⁰ _{-0.05}	35.32 ⁰ _{-0.18}	127 ⁰ _{-0.05}	48		19	7.94 ^{+0.03} ₀	114.5	Conforms to ISO 3019-1	BSP	Metric
A3HG37-FR01KK-J1D	M12	M10	22	18	G 1/2	56	12.7	31.75 ⁰ _{-0.05}	35.32 ⁰ _{-0.18}	127 ⁰ _{-0.05}	48		19	7.94 ^{+0.03} ₀	114.5	Conforms to ISO 3019-1	Rc	Metric

Drain Port

For Port/Flange Code "U1/J1", Adapter and bonded seal are attached. After installing the bonded seal at the drain port tighten the adapter

Detail:A3HG37-FR01KK-E1D/E2D

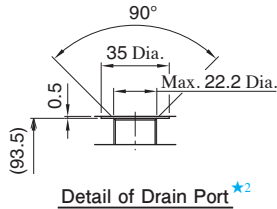

★2. Drain port conforms to ISO 9974-1, metric threads.

Accessories:A3HG37-FR01KK-U1D

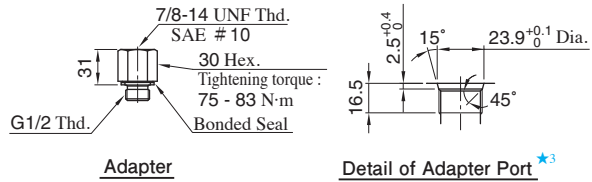

★3. Adapter port conforms to SAE J 514, O-Ring seals.

Detail:A3HG37-FR01KK-U2D

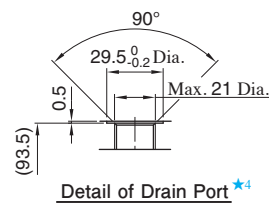

★4. Drain port conforms to ISO 1179-1, BSPP threads.

Accessories:A3HG37-FR01KK-J1D

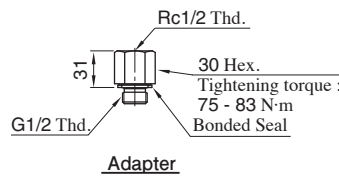

Foot Mtg. Four Bolts:A3HG37-LR01KK-E1D/E2D/U1D/U2D/J1D

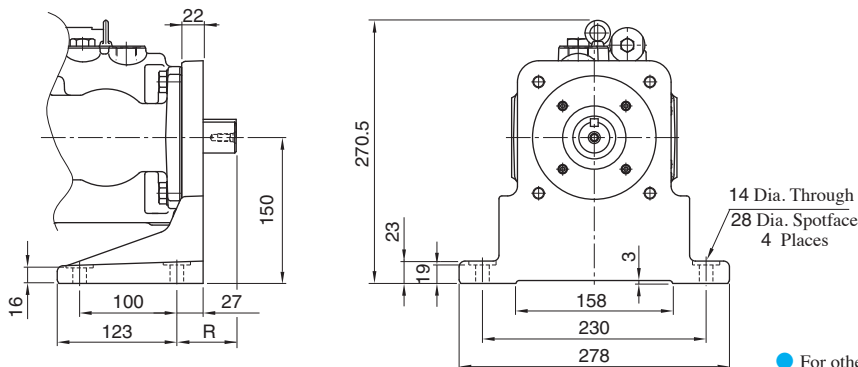

Model Numbers	R
A3HG37-LR01KK-E1D/E2D	65
A3HG37-LR01KK-U1D/U2D/J1D	61

★ For other dimensions, refer to "Flange Mtg. Four Bolts".

Flange Mtg.:A3HG71-FR01KK-E1D/E2D/U1D/U2D/J1D

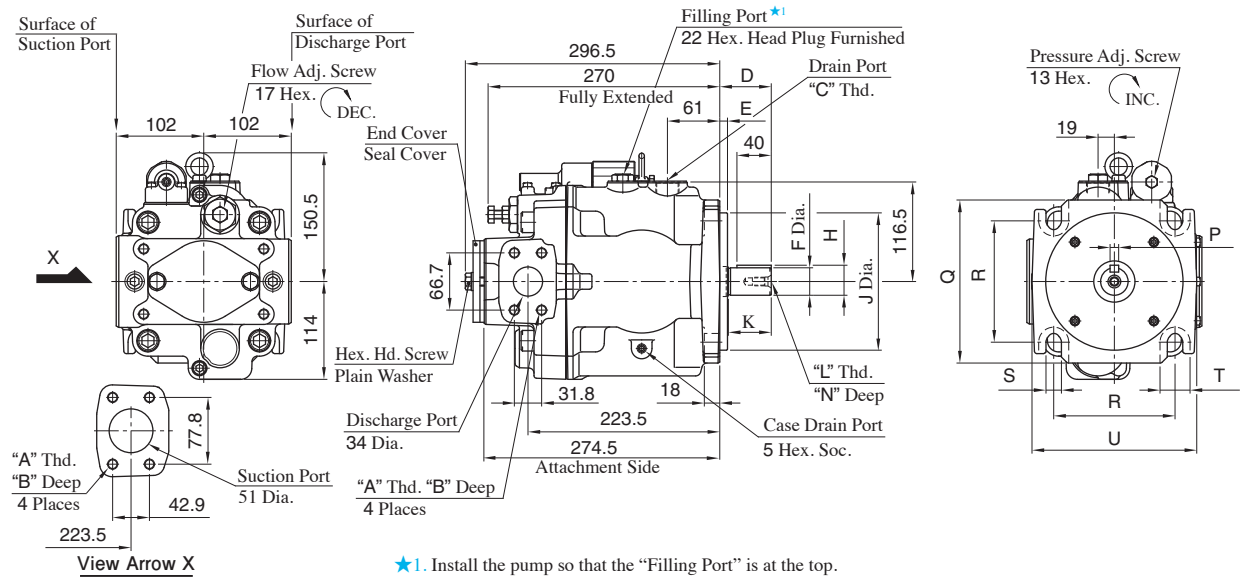

Model Numbers	A	B	C	D	E	F	H	J	K	L	N	P	Q	R	S	T	U	Mounting Flange	Connecting Port	Pipe Flange Threads
A3HG71-FR01KK-E1D/E2D	M12	22	M27X2	60	9	32 ^{+0.018} _{+0.002}	35 ^{+0.018} _{-0.288}	160 ⁰ _{-0.063}	50	M10	22	10 ⁰ _{-0.036}	190	141.4	18	35	192	Conforms to ISO 3019-2	Metric	Metric
A3HG71-FR01KK-U1D	1/2-13 UNC	21	G 3/4	56	12.7	31.75 ⁰ _{-0.05}	35.32 ⁰ _{-0.18}	127 ⁰ _{-0.05}	48		19	7.94 ^{+0.03} ₀	143	114.5	13.5	28	155	Conforms to ISO 3019-1	Unified	Unified
A3HG71-FR01KK-U2D	M12	22	G 3/4	56	12.7	31.75 ⁰ _{-0.05}	35.32 ⁰ _{-0.18}	127 ⁰ _{-0.05}	48	5/16-18 UNC	19	7.94 ^{+0.03} ₀	143	114.5	13.5	28	155	Conforms to ISO 3019-1	BSPP	Metric
A3HG71-FR01KK-J1D	M12	22	G 3/4	56	12.7	31.75 ⁰ _{-0.05}	35.32 ⁰ _{-0.18}	127 ⁰ _{-0.05}	48		19	7.94 ^{+0.03} ₀	143	114.5	13.5	28	155	Conforms to ISO 3019-1	Rc	Metric

Drain Port

For Port/Flange Code "U1/J1", Adapter and bonded seal are attached. After installing the bonded seal at the drain port tighten the adapter

Detail:A3HG71-FR01KK-E1D/E2D

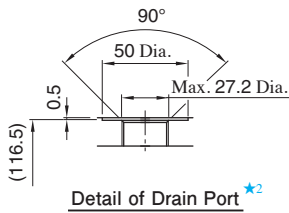

*2. Drain port conforms to ISO 9974-1, metric threads.

Accessories:A3HG71-FR01KK-U1D

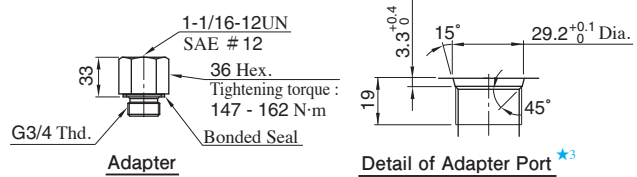

*3. Adapter port conforms to SAE J 514, O-Ring seals.

Detail:A3HG71-FR01KK-U2D

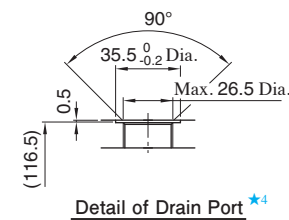

*4. Drain port conforms to ISO 1179-1, BSPP threads.

Accessories:A3HG71-FR01KK-J1D

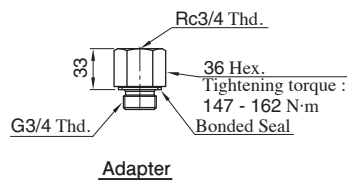

Foot Mtg.:A3HG71-LR01KK-E1D/E2D/U1D/U2D/J1D

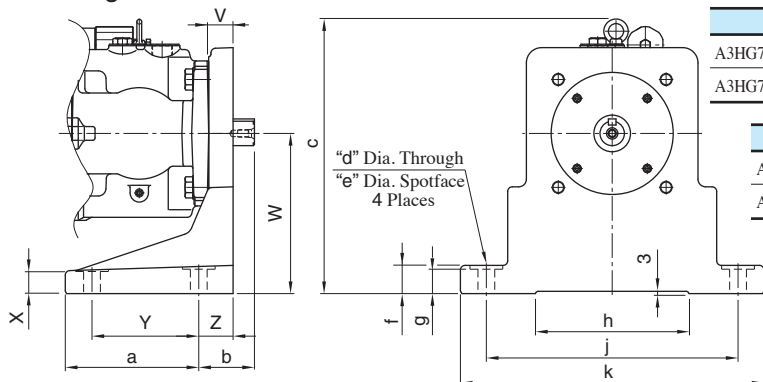

Model Numbers	V	W	X	Y	Z	a	b	c
A3HG71-LR01KK-E1D/E2D	32	210	29	140	45	175	73	360.5
A3HG71-LR01KK-U1D/U2D/J1D	22	150	16	100	27	123	61	300.5

Model Numbers	d	e	f	g	h	j	k
A3HG71-LR01KK-E1D/E2D	22	43	37	32	198	330	398
A3HG71-LR01KK-U1D/U2D/J1D	14	28	23	19	158	230	278

For other dimensions, refer to "Flange Mtg.".

Flange Mtg.:A3HG145-FR01KK-E1D/E2D/U1D/U2D/J1D

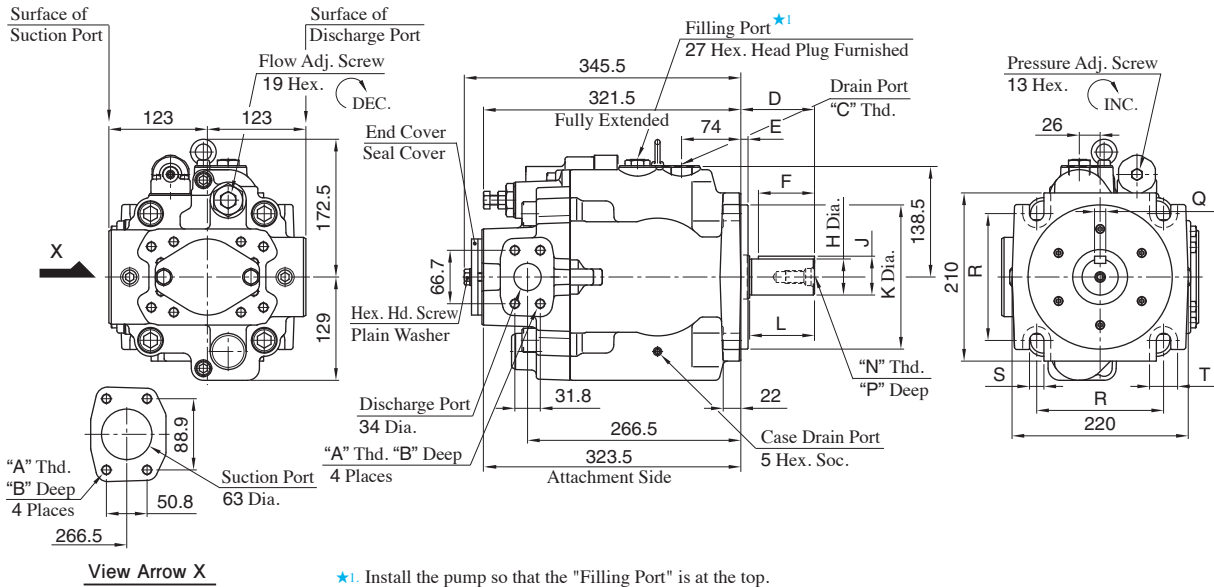

Model Numbers	A	B	C	D	E	F	H	J	K	L	N	P	Q	R	S	T	Mounting Flange	Connecting Port	Pipe Flange Threads
A3HG145-FR01KK-E1D/E2D	M12	22	M27X2	92	9	70	45 ^{+0.018} _{-0.002}	48.5 ^{+0.018} _{-0.288}	180 ⁰ _{-0.063}	82	M16	36	14 ⁰ _{-0.043}	158.4	18	35	Conforms to ISO 3019-2	Metric	Metric
A3HG145-FR01KK-U1D	1/2-13 UNC	21	G 3/4	75	12.7	56	44.45 ⁰ _{-0.05}	49.39 ⁰ _{-0.18}	152.4 ⁰ _{-0.05}	67		32	11.11 ^{+0.03} ₀	161.6	21.5	39	Conforms to ISO 3019-1	Unified	Unified
A3HG145-FR01KK-U2D	M12	22	G 3/4	75	12.7	56	44.45 ⁰ _{-0.05}	49.39 ⁰ _{-0.18}	152.4 ⁰ _{-0.05}	67	1/2-13 UNC	32	11.11 ^{+0.03} ₀	161.6	21.5	39	Conforms to ISO 3019-1	BSPP	Metric
A3HG145-FR01KK-J1D	M12	22	G 3/4	75	12.7	56	44.45 ⁰ _{-0.05}	49.39 ⁰ _{-0.18}	152.4 ⁰ _{-0.05}	67		32	11.11 ^{+0.03} ₀	161.6	21.5	39	Conforms to ISO 3019-1	Rc	Metric

Drain Port

For Port/Flange Code "U1/J1", Adapter and bonded seal are attached. After installing the bonded seal at the drain port tighten the adapter

Detail:A3HG145-FR01KK-E1D/E2D

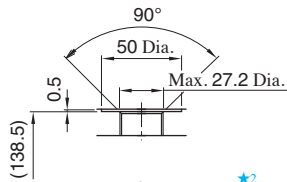

*2. Drain port conforms to ISO 9974-1, metric threads.

Accessories:A3HG145-FR01KK-U1D

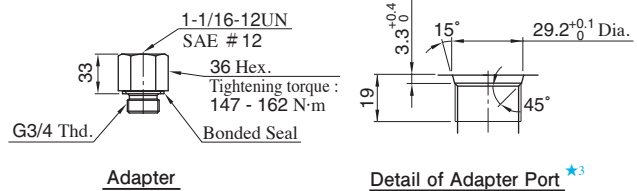

*3. Adapter port conforms to SAE J 514, O-Ring seals.

Detail:A3HG145-FR01KK-U2D

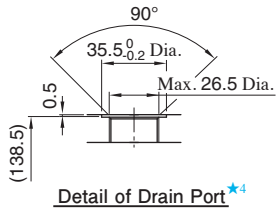

*4. Drain port conforms to ISO 1179-1, BSPP threads.

Accessories:A3HG145-FR01KK-J1D

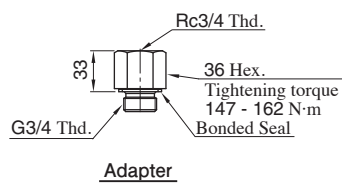

Foot Mtg.:A3HG145-LR01KK-E1D/E2D/U1D/U2D/J1D

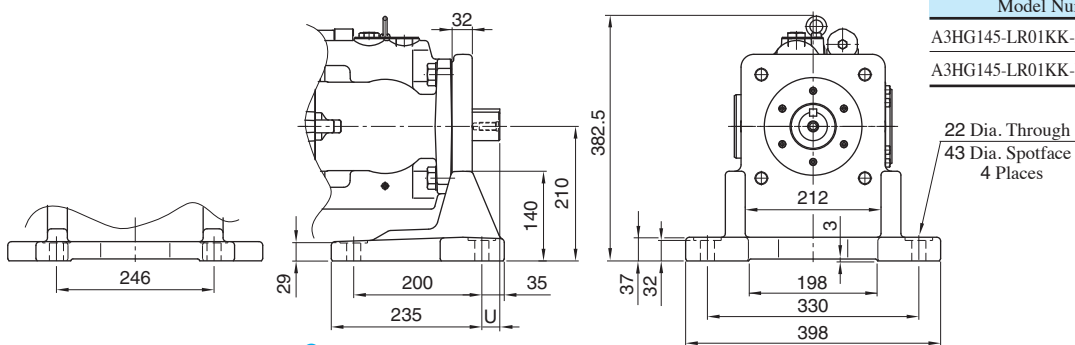

For other dimensions, refer to "Flange Mtg."

Model Numbers	U
A3HG145-LR01KK-E1D/E2D	45
A3HG145-LR01KK-U1D/U2D/J1D	28

Spear Parts List

A3HG *- * R01KK

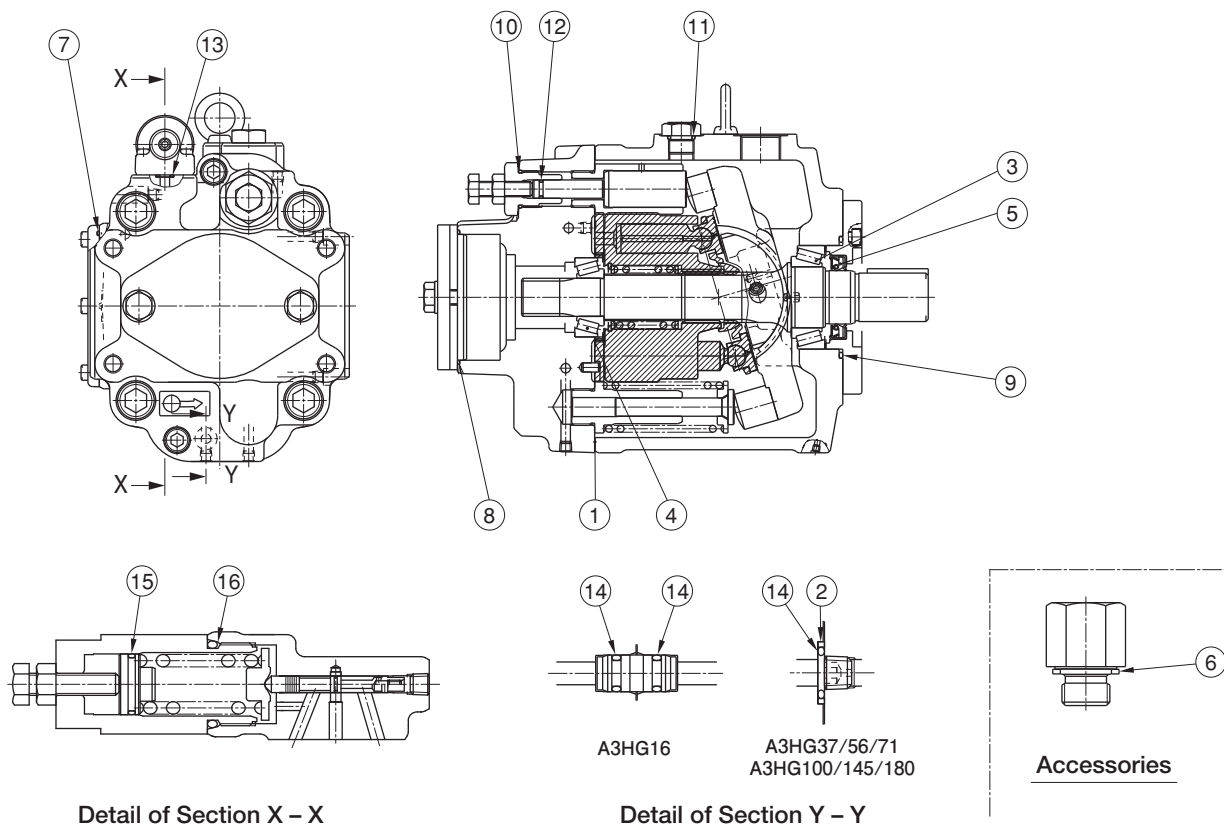

List of Seals and Bearings

Item	Name of Parts	Part Numbers							Q'ty.
		A3HG16	A3HG37	A3HG56	A3HG71	A3HG100	A3HG145	A3HG180	
1	Gasket	Z150-2270-PK314095-1	Z800-2271-PK314517-4	Z800-2272-PK314506-7	2283-PK212657-1	2284-PK212655-5	2285-PK212635-7	2286-PK212656-3	1
2	Back Up Ring	—	1310E-PK412440-0					—	1
3	Tapered Roller Bearing	—	HR33007J	4T-33008	33009JR	4T-30210	HR33011	—	1
	Cylindrical Roller Bearing	NUP205E	—	—	—	—	—	2276-PK412859-1	
4	Tapered Roller Bearing	—	4T-33005	4T-33205R	4T-33205	4T-33206	4T-33206	—	1
	Needle Roller Bearing	HMK2030V3	—	—	—	—	—	2276-PK412860-9	
5	Oil Seal	TCN254511 (FKM)	TCN355511 (FKM)	TCN355511 (FKM)	TCN355511 (FKM)	TCN507212 (FKM)	TCN557812 (FKM)	TCN557812 (FKM)	1
6	Bonded Seal★	KP-C-04 (FKM)	KP-C-04 (FKM)	KP-C-05 (FKM)	KP-C-05 (FKM)	KP-C-05 (FKM)	KP-C-05 (FKM)	KP-C-05 (FKM)	1
7	O-Ring	S65 (FKM-70)	S85 (FKM-70)	S95 (FKM-70)	S100 (FKM-70)	S110 (FKM-70)	S125 (FKM-70)	S130 (FKM-70)	1
8	O-Ring, Gasket	2280-PK413358-3	S80 (FKM-70)	S80 (FKM-70)	S80 (FKM-70)	S80 (FKM-70)	S80 (FKM-70)	S80 (FKM-70)	1
9	O-Ring	SO-FB-A139	SO-FA-G70	SO-FA-G75	SO-FA-G80	SO-FA-G95	SO-FA-G95	SO-FA-G105	1
10	O-Ring	SO-FB-P14	SO-FB-P18	SO-FB-P21	SO-FB-P24	SO-FB-P24	SO-FB-P26	SO-FB-P26	1
11	O-Ring	SO-FB-P14	SO-FB-P14	SO-FB-P14	SO-FB-P14	SO-FB-P18	SO-FB-P18	SO-FB-P18	1
12	O-Ring	SO-FB-P6	SO-FB-P8	SO-FB-P9	SO-FB-P9	SO-FB-P9	SO-FB-P10A	SO-FB-P10A	1
13	O-Ring	SO-FB-P9	SO-FB-P9	SO-FB-P9	SO-FB-P9	SO-FB-P9	SO-FB-P9	SO-FB-P9	3
14	O-Ring	SO-FB-P7	SO-FB-P9	SO-FB-P9	SO-FB-P9	SO-FB-P9	SO-FB-P9	SO-FB-P9	SO-FB-P7:2 SO-FB-P9:1
15	O-Ring	SO-FA-A018	SO-FA-A018	SO-FA-A018	SO-FA-A021	SO-FA-A021	SO-FA-A021	SO-FA-A021	1
16	O-Ring	SO-FB-P26	SO-FB-P26	SO-FB-P26	SO-FB-P32	SO-FB-P32	SO-FB-P32	SO-FB-P32	1

★ Attached only to the port/flange U1 or J1.

**A3HG Series high Pressure Variable Displacement Piston Pumps
Pilot Pressure Control Type Pressure Compensator**

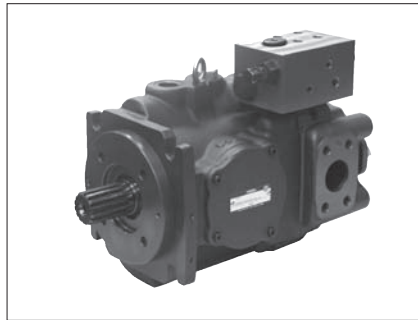

Graphic Symbol

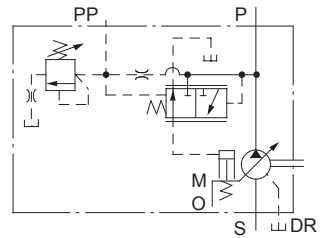

Specifications

Model Numbers	Geometric Displacement cm ³ /rev	Minimum Adjustment Flow cm ³ /rev	Operating Pressure MPa		Minimum Adjustment Pressure MPa	Shaft Speed Range r/min		Approx. Mass kg	
			Rated★1	Intermittent		Max.★2	Min.	Flange Mtg.	Foot Mtg.
A3HG16- *R07* - *C-10	16.3	8	31.5	35	5	3600	600	18.9	22.9
A3HG37- *R07* - *C-10	37.1	16				2700	600	28.5	37
A3HG37- *R07* - *D-10								36	
A3HG56- *R07* - *C-10	56.3	35				2500	600	36.5	45
A3HG56- *R07* - *D-10								34.5	42
A3HG71- *R07* -E1D/E2D-10	70.7	45				2300	600	47	73
A3HG71- *R07* -U1D/U2D/J1D-10							43.5	51	
A3HG100- *R07K-E1D/E2D-10	100.5	63			2100	600	58.5	83.5	
A3HG100- *R07SP* -E1D/E2D-10							58	83	
A3HG100- *R07* -U1D/U2D/J1D-10							58	85	
A3HG145- *R07K-E1D/E2D-10							70.5	96.5	
A3HG145- *R07SP* -E1D/E2D-10	145.2	95			1800	600	70	96	
A3HG145- *R07* -U1D/U2D/J1D-10							70	97.5	
A3HG180- *R07K-E1D/E2D-10							90	116	
A3HG180- *R07SP* -E1D/E2D-10							89.5	115.5	
A3HG180- *R07* -U1D/U2D/J1D-10	180.7	130			1800	600	89.5	117	

- ★1. Consult Yuken when pump is used over rated pressure because there is a restriction on operating condition.
- ★2. The maximum shaft speeds shown in the above table are at suction pressure 0 kPa.

Model Number Designation

A3HG16	-F	R	07	K	-E1					D	-10										
Series Number	Mounting	Direction of Rotation	Control Type	Shaft Extension	Main Pump Mtg. Flange Connecting Port / Pipe Flange Thread Second Pump Mtg.					Number of Pump Mtg. Bolts	Design Number										
A3HG16 (16.3 cm ³ /rev)	F: Flange Mtg. L: Foot Mtg.	(Viewed from Shaft End) R: Clockwise (Normal)	07: Pilot Pressure Control Type Pressure Compensator	K: Keyed Shaft SP: Splined Shaft (High torque) SP1: Splined Shaft (Conforms to ISO 3019-1)	Code	Main Pump Mtg. Flange	Connecting Port	Pipe Flange Thread	Second Pump Mtg.	C: 2 D: 4	10										
A3HG37 (37.1 cm ³ /rev)																					
A3HG56 (56.3 cm ³ /rev)																					
A3HG71 (70.7 cm ³ /rev)																					
A3HG100 (100.5 cm ³ /rev)																					
A3HG145 (145.2 cm ³ /rev)																					
A3HG180 (180.7 cm ³ /rev)																					

■ Pipe Flange Kits

Pipe flange mouting surface conforms to SAE J 518, 4 bolt split flange.
 Pipe flange kits are not available. Contact us for the details.

Typical Performance Characteristics of Type "A3HG71" at Viscosity 32 mm²/s [ISO VG32 oils, 40°C]

■ Pressure vs. Output Flow

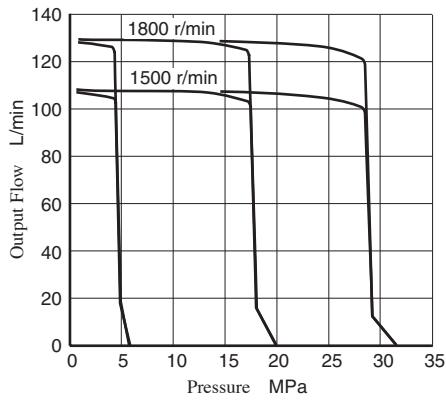

■ Full Cut-off Power

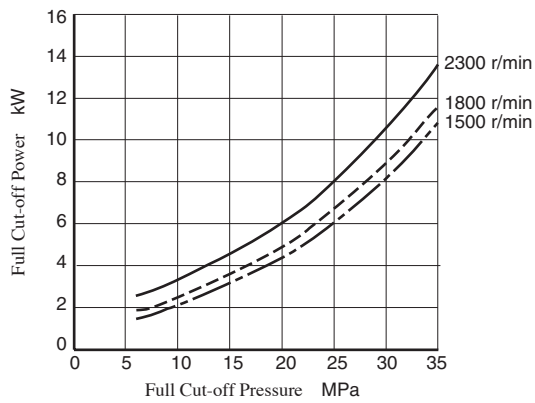

■ Full Cut-off Drain

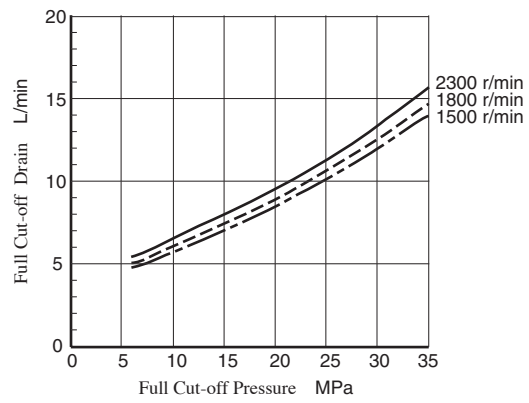

Flange Mtg.:A3HG16-FR07K-E1C/U1C/U2C/J1C

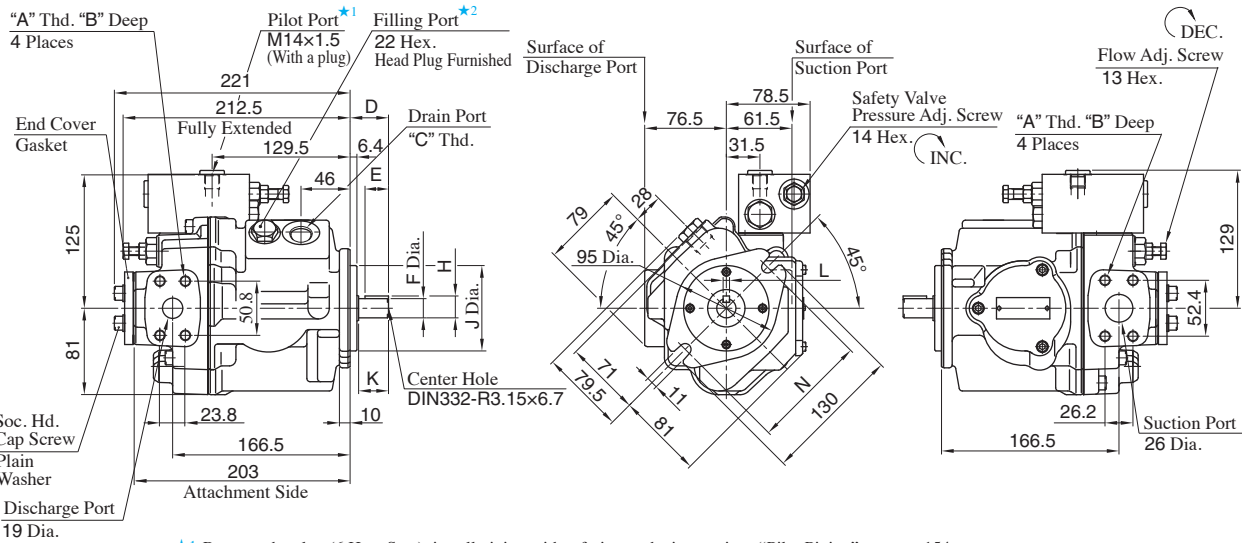

- ★1. Remove the plug (6 Hex. Soc.), install piping with referring to the instructions "Pilot Piping" on page 154.
- ★2. Install the pump so that the "Filling Port" is at the top.

Model Numbers	A	B	C	D	E	F	H	J	K	L	N	Mounting Flange	Connecting Port	Pipe Flange Threads
A3HG16-FR07K-E1C	M10	19	M22 x 1.5	36	22	18 ^{+0.008} _{-0.003}	20.5 ^{+0.008} _{-0.133}	80 ⁰ _{-0.046}	28	6 ⁰ _{-0.03}	109	Conforms to ISO 3019-2	Metric	Metric
A3HG16-FR07K-U1C	3/8-16 UNC	17	G 1/2	41	28	19.05 ⁰ _{-0.03}	21.24 ⁰ _{-0.16}	82.55 ⁰ _{-0.05}	33	4.76 ^{+0.03} ₀	106	Conforms to ISO 3019-1	Unified	Unified
A3HG16-FR07K-U2C	M10	19	G 1/2	41	28	19.05 ⁰ _{-0.03}	21.24 ⁰ _{-0.16}	82.55 ⁰ _{-0.05}	33	4.76 ^{+0.03} ₀	106	Conforms to ISO 3019-1	BSP	Metric
A3HG16-FR07K-J1C	M10	19	G 1/2	41	28	19.05 ⁰ _{-0.03}	21.24 ⁰ _{-0.16}	82.55 ⁰ _{-0.05}	33	4.76 ^{+0.03} ₀	106	Conforms to ISO 3019-1	Rc	Metric

Pilot Port

For Port/Flange Code "U1/U2/J1" Adapter and O-Ring are attached. After installing the O-Ring at the drain port tighten the adapter

● Detail:A3HG16-FR07K-E1C

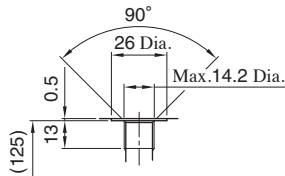

Detail of Pilot Port ★3

★3. Pilot port conforms to ISO 9974-1, metric threads.

● Accessories:A3HG16-FR07K-U2C

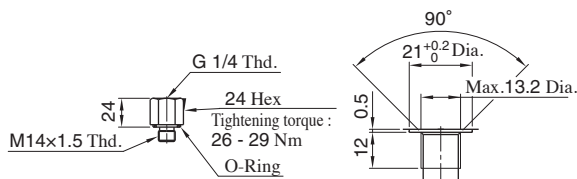

Adapter

Detail of Adapter Port ★5

★5. Adapter port conforms to ISO 1179-1, BSPP threads.

● Accessories:A3HG16-FR07K-U1C

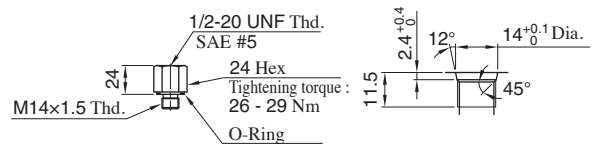

Adapter

Detail of Adapter Port ★4

★4. Adapter port conforms to SAE J 514, O-Ring seals

● Accessories:A3HG16-FR07K-J1C

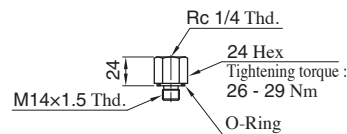

Adapter

Drain Port

Drain Port is common to that of pressure compensator model. Refer to page 167 for the dimensions of Drain Port.

Foot Mtg.:A3HG16-LR07K-E1C/U1C/U2C/J1C

Mounting bracket is common to that of pressure compensator model (except max height dimension). Refer to page 167 for the dimensions of mounting bracket.

Flange Mtg.:A3HG71-FR07K-E1D/E2D/U1D/U2D/J1D

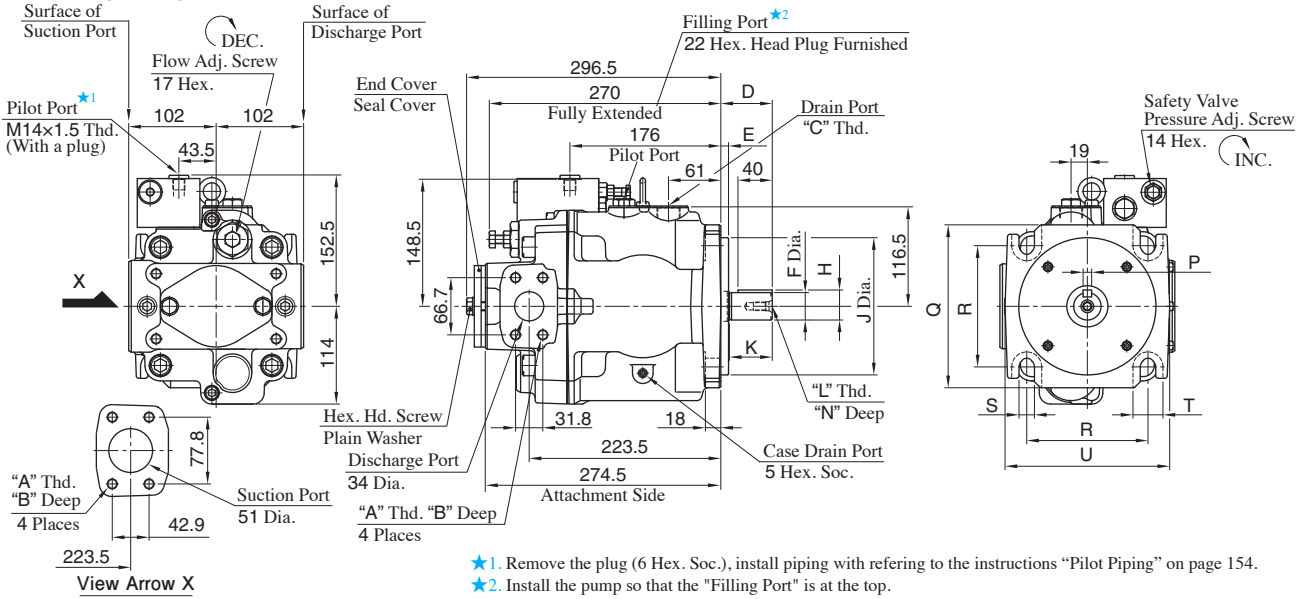

Model Numbers	A	B	C	D	E	F	H	J	K	L	N	P	Q	R	S	T	U	Mounting Flange	Connecting Port	Pipe Flange Threads
A3HG71-FR07K-E1D/E2D	M12	22	M27x2	60	9	32 ^{+0.018} / _{+0.002}	35 ^{+0.018} / _{-0.288}	160 ⁰ / _{-0.063}	50	M10	22	10 ⁰ / _{-0.036}	190	141.4	18	35	192	Conforms to ISO 3019-2	Metric	Metric
A3HG71-FR07K-U1D	1/2-13 UNC	21	G 3/4	56	12.7	31.75 ⁰ / _{-0.05}	35.32 ⁰ / _{-0.18}	127 ⁰ / _{-0.05}	48		19	7.94 ^{+0.03} / ₀	143	114.5	13.5	28	155	Conforms to ISO 3019-1	Unified	Unified
A3HG71-FR07K-U2D	M12	22	G 3/4	56	12.7	31.75 ⁰ / _{-0.05}	35.32 ⁰ / _{-0.18}	127 ⁰ / _{-0.05}	48	5/16-18 UNC	19	7.94 ^{+0.03} / ₀	143	114.5	13.5	28	155	Conforms to ISO 3019-1	BSP	Metric
A3HG71-FR07K-J1D	M12	22	G 3/4	56	12.7	31.75 ⁰ / _{-0.05}	35.32 ⁰ / _{-0.18}	127 ⁰ / _{-0.05}	48		19	7.94 ^{+0.03} / ₀	143	114.5	13.5	28	155	Conforms to ISO 3019-1	Re	Metric

Flange Mtg.:A3HG100-FR07K-E1D/E2D/U1D/U2D/J1D

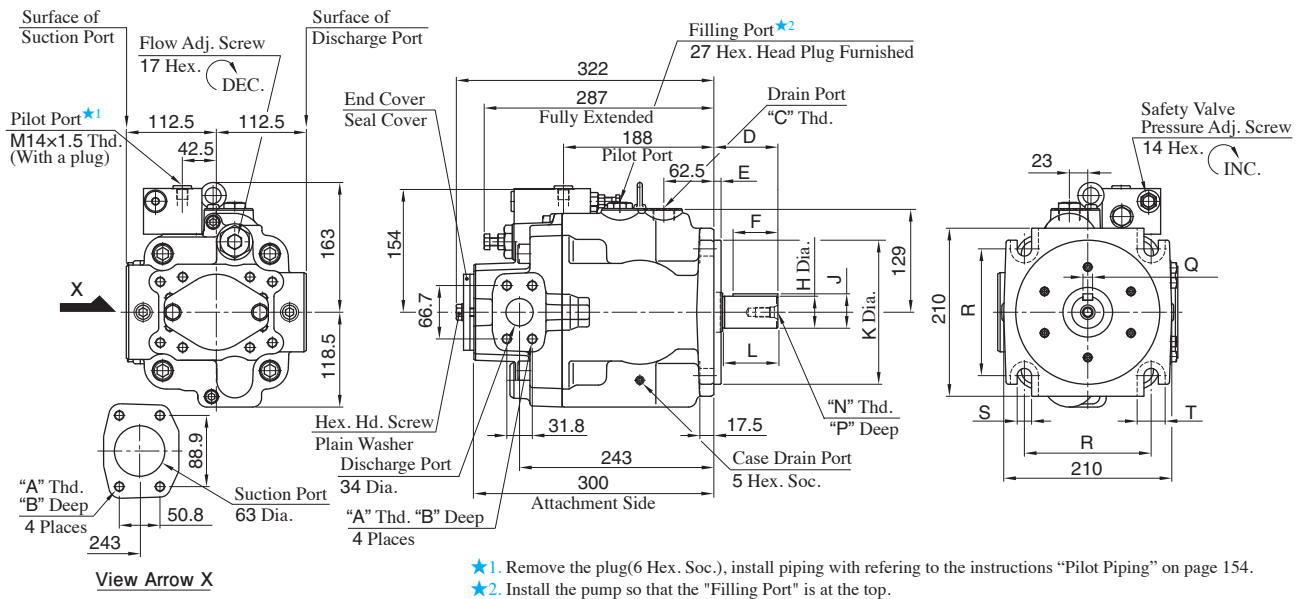

Model Numbers	A	B	C	D	E	F	H	J	K	L	N	P	Q	R	S	T	U	Mounting Flange	Connecting Port	Pipe Flange Threads
A3HG100-FR07K-E1D/E2D	M12	22	M27x2	80	9	56	40 ^{+0.018} / _{+0.002}	43 ^{+0.018} / _{-0.288}	180 ⁰ / _{-0.063}	70	M12	28	12 ⁰ / _{-0.043}	158.4	18	35		Conforms to ISO 3019-2	Metric	Metric
A3HG100-FR07K-U1D	1/2-13 UNC	21	G 3/4	62	12.7	45	38.1 ⁰ / _{-0.05}	42.36 ⁰ / _{-0.18}	152.4 ⁰ / _{-0.05}	54		28	9.53 ^{+0.03} / ₀	161.6	21.5	39		Conforms to ISO 3019-1	Unified	Unified
A3HG100-FR07K-U2D	M12	22	G 3/4	62	12.7	45	38.1 ⁰ / _{-0.05}	42.36 ⁰ / _{-0.18}	152.4 ⁰ / _{-0.05}	54	7/16-14 UNC	28	9.53 ^{+0.03} / ₀	161.6	21.5	39		Conforms to ISO 3019-1	BSP	Metric
A3HG100-FR07K-J1D	M12	22	G 3/4	62	12.7	45	38.1 ⁰ / _{-0.05}	42.36 ⁰ / _{-0.18}	152.4 ⁰ / _{-0.05}	54		28	9.53 ^{+0.03} / ₀	161.6	21.5	39		Conforms to ISO 3019-1	Re	Metric

Pilot Port

Pilot Port is common to that of "A3HG16-FR07K-E1C/U1C/U2C/J1C" (except the height dimension from the center of the pump). Refer to page 179 for the dimensions of Pilot Port.

Drain Port

Drain Port is common to that of pressure compensator model. Refer to page 172 or 173 for the dimensions of Drain Port.

Foot Mtg.:A3HG71-LR07K-E1D/E2D/U1D/U2D/J1D, A3HG100-LR07K-E1D/E2D/U1D/U2D/J1D

Mounting bracket is common to that of pressure compensator model. Refer to page 172 and 173 for the dimensions of mounting bracket.

A3HG Series high Pressure Variable Displacement Piston Pumps Constant Power Control Type With External Pilot

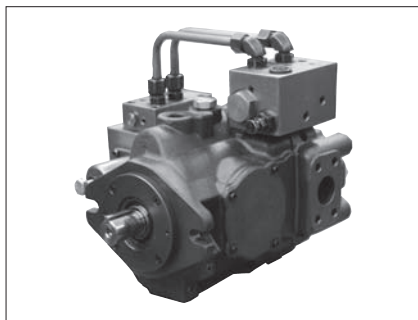

Graphic Symbol

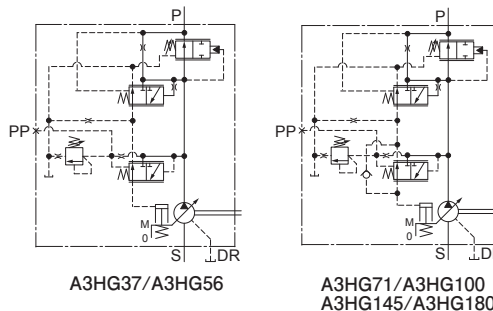

Specifications

Model Numbers	Geometric Displacement cm ³ /rev	Minimum Adjustment Flow cm ³ /rev	Operating Pressure MPa		Minimum Adjustment Pressure MPa	Shaft Speed Range r/min		Approx. Mass kg		
			Rated ^{★1}	Intermittent		Max. ^{★2}	Min.	Flange Mtg.	Foot Mtg.	
A3HG37- *R09V * - * - * C-10	37.1	16	31.5	35	5	2700	600	37	45.5	
A3HG37- *R09V * - * - * D-10									44.5	
A3HG56- *R09V * - * - * C-10	56.3	35				2500	600	45	53.5	
A3HG56- *R09V * - * - * D-10									43	50.5
A3HG71- *R09V * - * - * E1D/E2D-10	70.7	45				2300	600	56	82	
A3HG71- *R09V * - * - * U1D/U2D/J1D-10									52.5	60
A3HG100- *R09V * - * - * K-E1D/E2D-10	100.5	63				2100	600	67.5	92.5	
A3HG100- *R09V * - * - * SP * -E1D/E2D-10									67	92
A3HG100- *R09V * - * - * U1D/U2D/J1D-10									67	94
A3HG145- *R09V * - * - * K-E1D/E2D-10	145.2	95				1800	600	83.5	109.5	
A3HG145- *R09V * - * - * SP * -E1D/E2D-10									83	109
A3HG145- *R09V * - * - * U1D/U2D/J1D-10									83	110.5
A3HG180- *R09V * - * - * K-E1D/E2D-10	180.7	130	1800	600	101	127				
A3HG180- *R09V * - * - * SP * -E1D/E2D-10						100.5	126.5			
A3HG180- *R09V * - * - * U1D/U2D/J1D-10						100.5	128			

★1. Consult Yuken when pump is used over rated pressure because there is a restriction on operating condition.

★2. The maximum shaft speeds shown in the above table are at suction pressure 0 kPa.

Model Number Designation

A3HG37	-F	R	09V	B	-K	-E1				D	-10		
Series Number	Mounting	Direction of Rotation	Control Type	Input Power Setting	Shaft Extension	Main Pump Mtg. Flange Connecting Port / Pipe Flange Thread Second Pump Mtg.				Number of Pump Mtg. Bolts	Design Number		
A3HG37 (37.1 cm ³ /rev)	F: Flange Mtg.	(Viewed from Shaft End)	09V: Constant Power Control Type With External Pilot	B:7.5 kW N:110 kW	K: Keyed Shaft	Code	Main Pump Mtg. Flange	Connecting Port	Pipe Flange Thread	Second Pump Mtg.	C: 2 D: 4	10	
A3HG56 (56.3 cm ³ /rev)													
A3HG71 (70.7 cm ³ /rev)	L: Foot Mtg.	R: Clockwise (Normal)		Refer to the table on following page for combination.	SP: Splined Shaft (High torque)	SP1: Splined Shaft (Conforms to ISO 3019-1)	E1	ISO 3019-2	Metric	Metric	ISO 3019-2	D: 4	10
A3HG100 (100.5 cm ³ /rev)							E2	ISO 3019-2	Metric	Metric	ISO 3019-1		10
A3HG145 (145.2 cm ³ /rev)				U1	ISO 3019-1	Unified	Metric	ISO 3019-1	10				
				U2	ISO 3019-1	BSPP	Metric	ISO 3019-1	10				
A3HG180 (180.7 cm ³ /rev)					J1	ISO 3019-1	Rc	Metric	ISO 3019-1		10		

Combination of pump series and input power setting

Mark "○" in the table below refers to available combinations.

Model Numbers	Input Power Setting kW											
	B: 7.5	C: 11	D: 15	E: 18.5	F: 22	G: 30	H: 37	J: 45	K: 55	L: 75	M: 90	N: 110
A3HG37	○	○	○	○	○							
A3HG56		○	○	○	○	○	○					
A3HG71			○	○	○	○	○	○				
A3HG100				○	○	○	○	○	○			
A3HG145					○	○	○	○	○	○	○	
A3HG180						○	○	○	○	○	○	○

Pipe Flange Kits

Pipe flange mouting surface conforms to SAE J 518, 4 bolt split flange.

Pipe flange kits are not available. Contact us for the details.

Typical Performance Characteristics of Type "A3HG37/56/71" at Viscosity 32 mm²/s [ISO VG32 oils, 40°C]

A3HG37

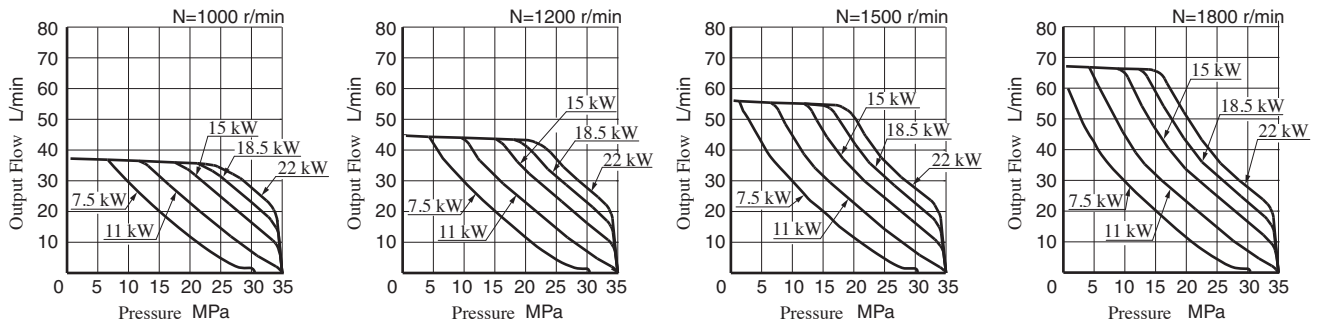

A3HG56

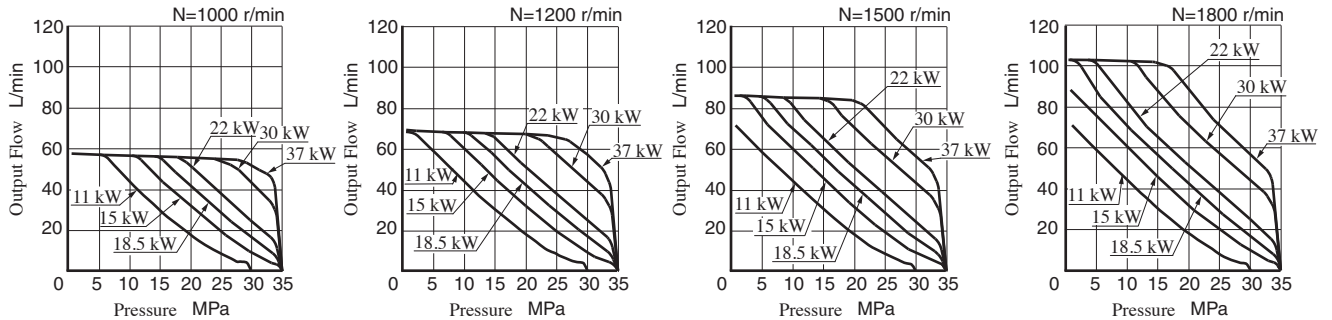

A3HG71

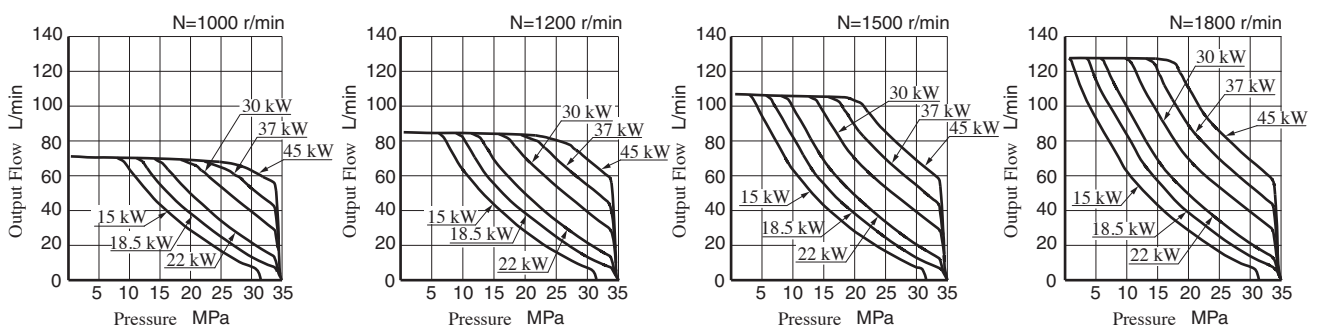

★1. Pumps are adjusted to the required power before shipment, but in case of oil temperature raise (increase of drain) the input power may exceed the adjusted power. In that case phase re-adjust screw referring to instruction manual.

★2. In case of over 1800 r/min of shaft speed, the input power may exceed the adjusted power. In that case phase re-adjust screw referring to instruction manual.

Typical Performance Characteristics of Type "A3HG100/145/180" at Viscosity 32 mm²/s [ISO VG32 oils, 40°C]

● A3HG100

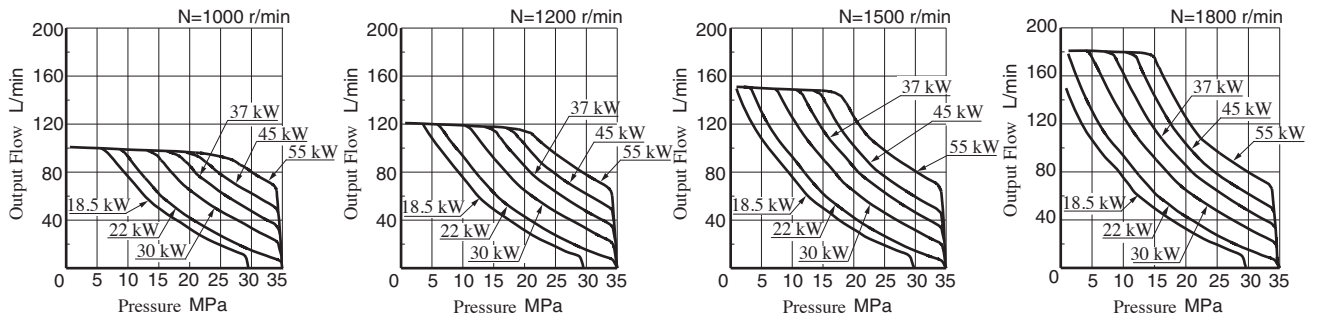

● A3HG145

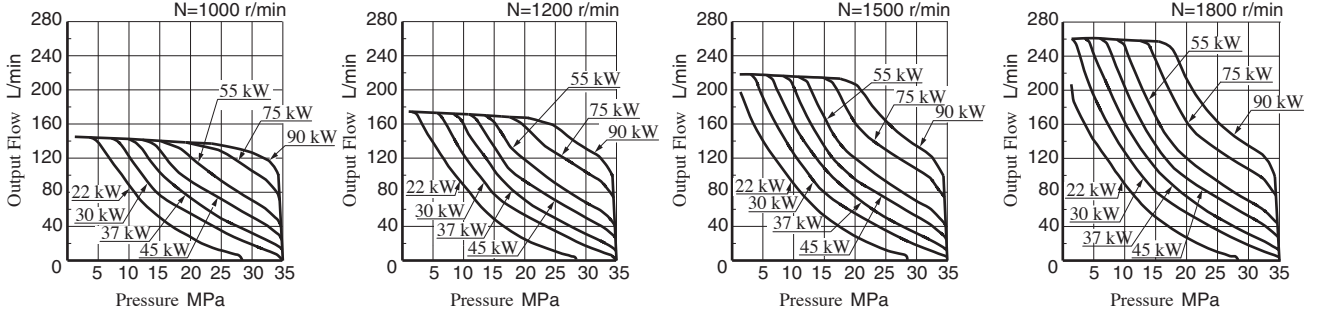

● A3HG180

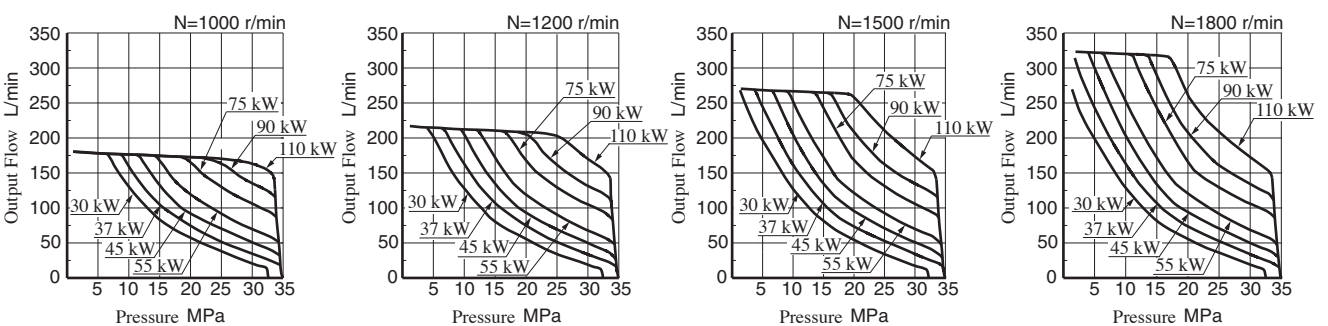

- ★1. Pumps are adjusted to the required power before shipment, but in case of oil temperature raise (increase of drain) the input power may exceed the adjusted power. In that case phase re-adjust screw referring to instruction manual.
- ★2. In case of over 1800 r/min of shaft speed, the input power may exceed the adjusted power. In that case phase re-adjust screw referring to instruction manual (except the model of "A3HG145/A3HG180").

Flange Mtg. Two Bolts:A3HG37-FR09V*-K-E1C/E2C/U1C/U2C/J1C

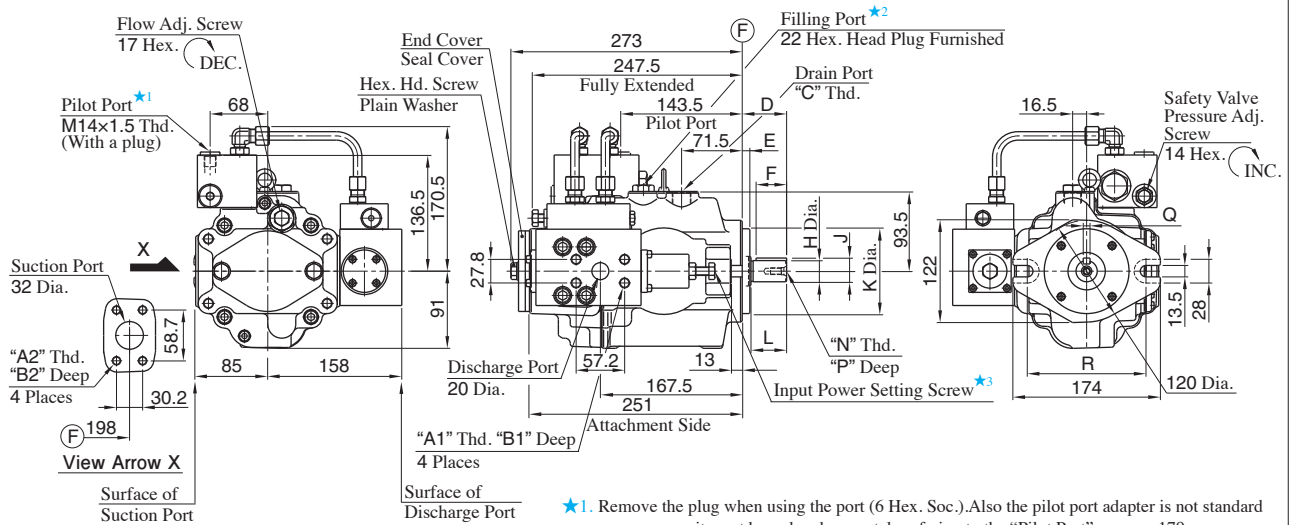

- ★1. Remove the plug when using the port (6 Hex. Soc.).Also the pilot port adapter is not standard accessory, so it must be ordered separately referring to the "Pilot Port" on page 179.
- ★2. Install the pump so that the "Filling Port" is at the top.
- ★3. Do not touch the screw because it is adjusted at the time of shipment.

Model Numbers	A1	A2	B1	B2	C	D	E	F	H	J	K	L	N	P	Q	R	Mounting Flange	Connecting Port	Pipe Flange Threads
A3HG37-FR09V*-K-E1C/E2C	M12	M10	22	18	M22X1.5	52	9	36	25 ^{+0.009} _{-0.004}	28 ^{+0.009} _{-0.294}	100 ⁰ _{-0.054}	42	M8	19	8 ⁰ _{-0.036}	140	Conforms to ISO 3019-2	Metric	Metric
A3HG37-FR09V*-K-U1C	7/16-14 UNC		20		G 1/2	46	9.7	32	25.4 ⁰ _{-0.05}	28.18 ⁰ _{-0.18}	101.6 ⁰ _{-0.05}	38	1/4-20 UNC	16	6.35 ^{+0.03} ₀	146	Conforms to ISO 3019-1	Unified	Unified
A3HG37-FR09V*-K-U2C	M12	M10	22	18	G 1/2	46	9.7	32	25.4 ⁰ _{-0.05}	28.18 ⁰ _{-0.18}	101.6 ⁰ _{-0.05}	38		16	6.35 ^{+0.03} ₀	146	Conforms to ISO 3019-1	BSP	Metric
A3HG37-FR09V*-K-J1C	M12	M10	22	18	G 1/2	46	9.7	32	25.4 ⁰ _{-0.05}	28.18 ⁰ _{-0.18}	101.6 ⁰ _{-0.05}	38	16	6.35 ^{+0.03} ₀	146	Conforms to ISO 3019-1	Rc	Metric	

Flange Mtg. Four Bolts:A3HG37-FR09V*-K-E1D/E2D/U1D/U2D/J1D

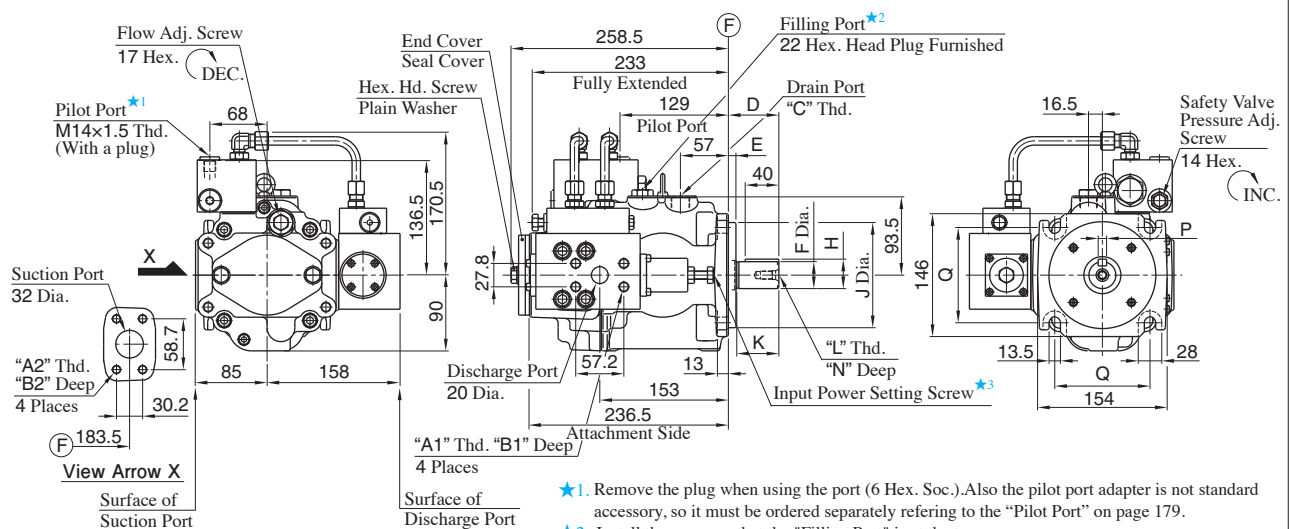

- ★1. Remove the plug when using the port (6 Hex. Soc.).Also the pilot port adapter is not standard accessory, so it must be ordered separately referring to the "Pilot Port" on page 179.
- ★2. Install the pump so that the "Filling Port" is at the top.
- ★3. Do not touch the screw because it is adjusted at the time of shipment.

Model Numbers	A1	A2	B1	B2	C	D	E	F	H	J	K	L	N	P	Q	Mounting Flange	Connecting Port	Pipe Flange Threads	
A3HG37-FR09V*-K-E1D/E2D	M12	M10	22	18	M22X1.5	60	9	32	31.75 ^{+0.018} _{+0.002}	35 ^{+0.018} _{-0.288}	125 ⁰ _{-0.063}	50	M10	22	10 ⁰ _{-0.036}	113.2	Conforms to ISO 3019-2	Metric	Metric
A3HG37-FR09V*-K-U1D	7/16-14 UNC		20		G 1/2	56	12.7	31.75 ⁰ _{-0.05}	35.32 ⁰ _{-0.18}	127 ⁰ _{-0.05}	48	5/16-18 UNC	19	7.94 ^{+0.03} ₀	114.5	Conforms to ISO 3019-1	Unified	Unified	
A3HG37-FR09V*-K-U2D	M12	M10	22	18	G 1/2	56	12.7	31.75 ⁰ _{-0.05}	35.32 ⁰ _{-0.18}	127 ⁰ _{-0.05}	48		19	7.94 ^{+0.03} ₀	114.5	Conforms to ISO 3019-1	BSP	Metric	
A3HG37-FR09V*-K-J1D	M12	M10	22	18	G 1/2	56	12.7	31.75 ⁰ _{-0.05}	35.32 ⁰ _{-0.18}	127 ⁰ _{-0.05}	48	19	7.94 ^{+0.03} ₀	114.5	Conforms to ISO 3019-1	Rc	Metric		

Pilot Port

Pilot Port is common to that of "A3HG16-FR07K-E1C/U1C/U2C/J1C"(except the height dimension from the center of the pump). Refer to page 179 for the dimensions of Pilot Port.

Drain Port

Drain Port is common to that of pressure compensator model.Refer to page 168 or 169 for the dimensions of Drain Port.

Foot Mtg.:A3HG37-LR09V*-K-E1C/E2C/U1C/U2C/J1C, A3HG37-LR09V*-K-E1D/E2D/U1D/U2D/J1D

Mounting bracket is common to that of pressure compensator model (except max height dimension). Refer to page 168 and 169 for the dimensions of mounting bracket.

Flange Mtg.:A3HG71-FR09V*-K-E1D/E2D/U1D/U2D/J1D

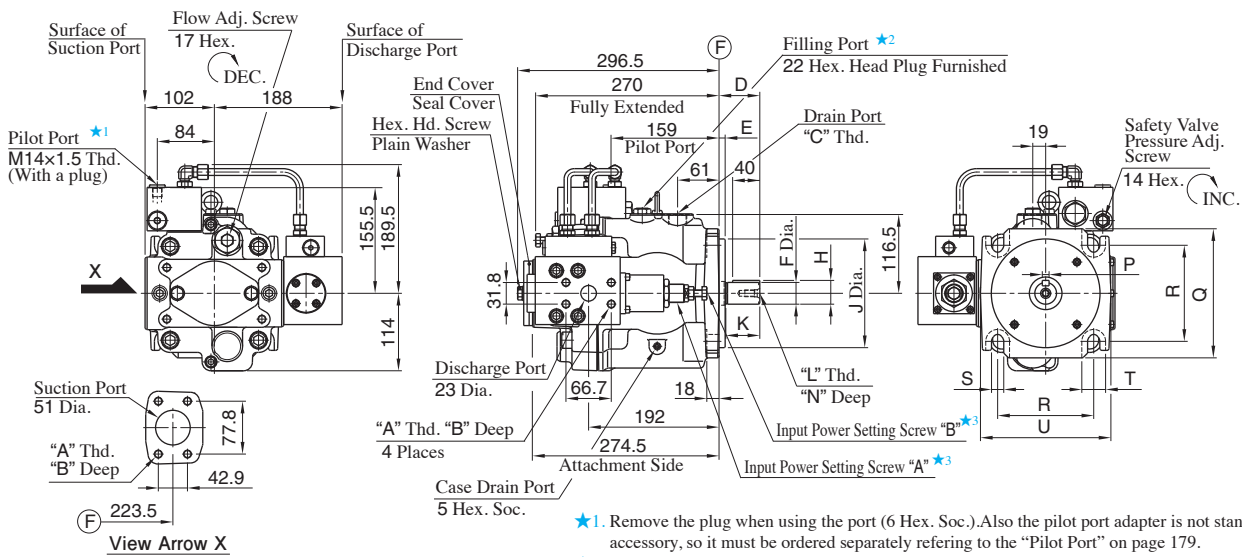

- ★1. Remove the plug when using the port (6 Hex. Soc.).Also the pilot port adapter is not standard accessory, so it must be ordered separately referring to the "Pilot Port" on page 179.
- ★2. Install the pump so that the "Filling Port" is at the top.
- ★3. Do not touch the screw because it is adjusted at the time of shipment.

Model Numbers	A	B	C	D	E	F	H	J	K	L	N	P	Q	R	S	T	U	Mounting Flange	Connecting Port	Pipe Flange Threads
A3HG71-FR09V*-K-E1D/E2D	M12	22	M27X2	60	9	32 ^{+0.018} _{-0.002}	35 ^{+0.018} _{-0.288}	160 ⁰ _{-0.063}	50	M10	22	10 ⁰ _{-0.036}	190	141.4	18	35	192	Conforms to ISO 3019-2	Metric	Metric
A3HG71-FR09V*-K-U1D	1/2-13 UNC	21	G 3/4	56	12.7	31.75 ⁰ _{-0.05}	35.32 ⁰ _{-0.18}	127 ⁰ _{-0.05}	48	5/16-18 UNC	19	7.94 ^{+0.03} ₀	143	114.5	13.5	28	155	Conforms to ISO 3019-1	Unified	Unified
A3HG71-FR09V*-K-U2D	M12	22	G 3/4	56	12.7	31.75 ⁰ _{-0.05}	35.32 ⁰ _{-0.18}	127 ⁰ _{-0.05}	48	5/16-18 UNC	19	7.94 ^{+0.03} ₀	143	114.5	13.5	28	155	Conforms to ISO 3019-1	BSP	Metric
A3HG71-FR09V*-K-J1D	M12	22	G 3/4	56	12.7	31.75 ⁰ _{-0.05}	35.32 ⁰ _{-0.18}	127 ⁰ _{-0.05}	48	5/16-18 UNC	19	7.94 ^{+0.03} ₀	143	114.5	13.5	28	155	Conforms to ISO 3019-1	Rc	Metric

Flange Mtg.:A3HG100-FR09V*-K-E1D/E2D/U1D/U2D/J1D

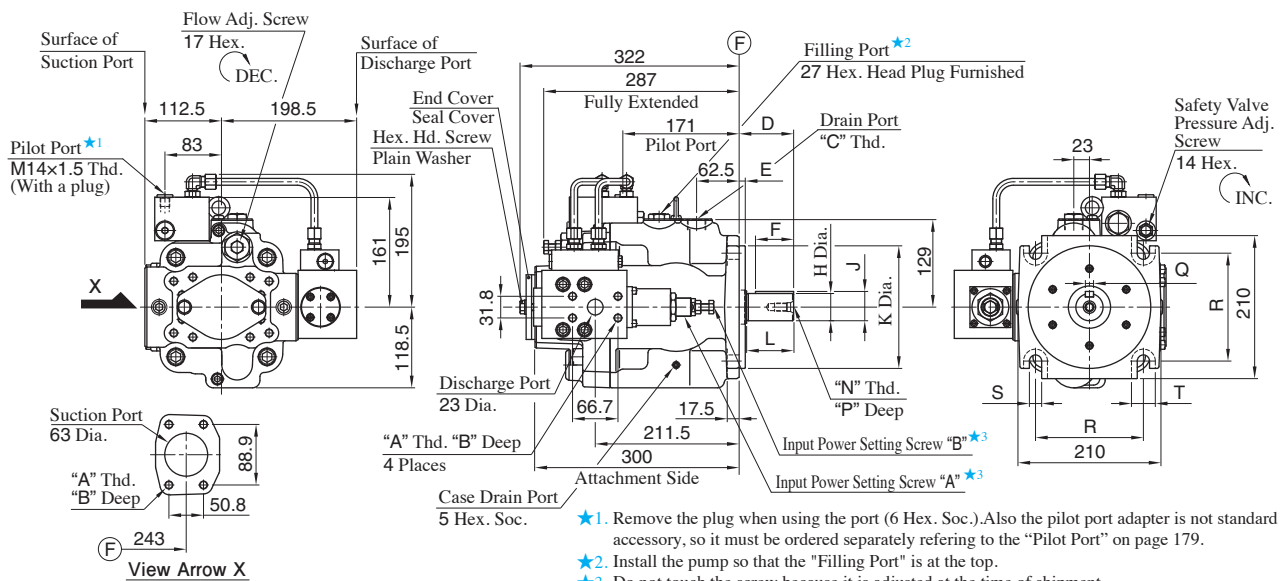

- ★1. Remove the plug when using the port (6 Hex. Soc.).Also the pilot port adapter is not standard accessory, so it must be ordered separately referring to the "Pilot Port" on page 179.
- ★2. Install the pump so that the "Filling Port" is at the top.
- ★3. Do not touch the screw because it is adjusted at the time of shipment.

Model Numbers	A	B	C	D	E	F	H	J	K	L	N	P	Q	R	S	T	U	Mounting Flange	Connecting Port	Pipe Flange Threads
A3HG100-FR09V*-K-E1D/E2D	M12	22	M27X2	80	9	40 ^{+0.018} _{-0.002}	43 ^{+0.018} _{-0.288}	180 ⁰ _{-0.063}	70	M12	28	12 ⁰ _{-0.043}	158.4	18	35	192	Conforms to ISO 3019-2	Metric	Metric	
A3HG100-FR09V*-K-U1D	1/2-13 UNC	21	G 3/4	62	12.7	38.1 ⁰ _{-0.05}	42.36 ⁰ _{-0.18}	152.4 ⁰ _{-0.05}	54	7/16-14 UNC	28	9.53 ^{+0.03} ₀	161.6	21.5	39	192	Conforms to ISO 3019-1	Unified	Unified	
A3HG100-FR09V*-K-U2D	M12	22	G 3/4	62	12.7	38.1 ⁰ _{-0.05}	42.36 ⁰ _{-0.18}	152.4 ⁰ _{-0.05}	54	7/16-14 UNC	28	9.53 ^{+0.03} ₀	161.6	21.5	39	192	Conforms to ISO 3019-1	BSP	Metric	
A3HG100-FR09V*-K-J1D	M12	22	G 3/4	62	12.7	38.1 ⁰ _{-0.05}	42.36 ⁰ _{-0.18}	152.4 ⁰ _{-0.05}	54	7/16-14 UNC	28	9.53 ^{+0.03} ₀	161.6	21.5	39	192	Conforms to ISO 3019-1	Rc	Metric	

Pilot Port

Pilot Port is common to that of "A3HG16-FR07K-E1C/U1C/U2C/J1C"(except the height dimension from the center of the pump). Refer to page 179 for the dimensions of Pilot Port.

Drain Port

Drain Port is common to that of pressure compensator model.Refer to page 172 or 173 for the dimensions of Drain Port.

Foot Mtg.:A3HG71-LR09V*-K-E1D/E2D/U1D/U2D/J1D, A3HG100-LR09V*-K-E1D/E2D/U1D/U2D/J1D

Mounting bracket is common to that of pressure compensator model (except max height dimension). Refer to page 172 and 173 for the dimensions of mounting bracket.

Flange Mtg.:A3HG145-FR09V*-K-E1D/E2D/U1D/U2D/J1D

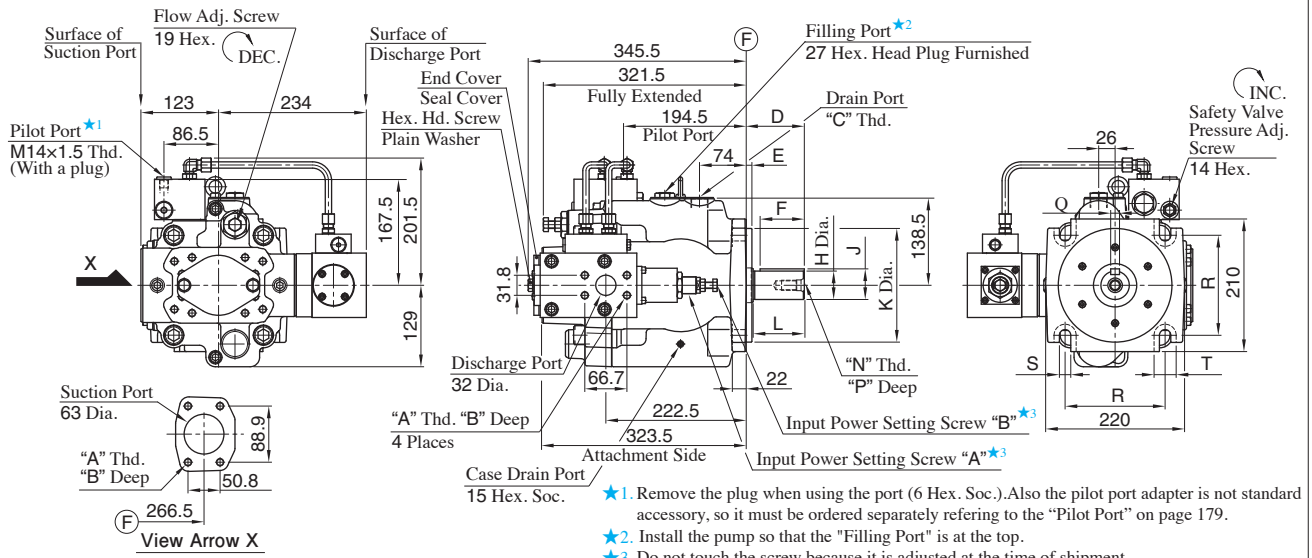

Model Numbers	A	B	C	D	E	F	H	J	K	L	N	P	Q	R	S	T	Mounting Flange	Connecting Port	Pipe Flange Threads
A3HG145-FR09V*-K-E1D/E2D	M12	22	M27X2	92	9	70	45 ^{+0.018} / _{-0.002}	48.5 ^{+0.018} / _{-0.288}	180 ⁰ / _{-0.063}	82	M16	36	14 ⁰ / _{-0.043}	158.4	18	35	Conforms to ISO 3019-2	Metric	Metric
A3HG145-FR09V*-K-U1D	1/2-13 UNC	21	G 3/4	75	12.7	56	44.45 ⁰ / _{-0.05}	49.39 ⁰ / _{-0.18}	152.4 ⁰ / _{-0.05}	67		32	11.11 ^{+0.03} / ₀	161.6	21.5	39	Conforms to ISO 3019-1	Unified	Unified
A3HG145-FR09V*-K-U2D	M12	22	G 3/4	75	12.7	56	44.45 ⁰ / _{-0.05}	49.39 ⁰ / _{-0.18}	152.4 ⁰ / _{-0.05}	67	1/2-13 UNC	32	11.11 ^{+0.03} / ₀	161.6	21.5	39	Conforms to ISO 3019-1	BSPP	Metric
A3HG145-FR09V*-K-J1D	M12	22	G 3/4	75	12.7	56	44.45 ⁰ / _{-0.05}	49.39 ⁰ / _{-0.18}	152.4 ⁰ / _{-0.05}	67		32	11.11 ^{+0.03} / ₀	161.6	21.5	39	Conforms to ISO 3019-1	Rc	Metric

Flange Mtg.:A3HG180-FR09V*-K-E1D/E2D/U1D/U2D/J1D

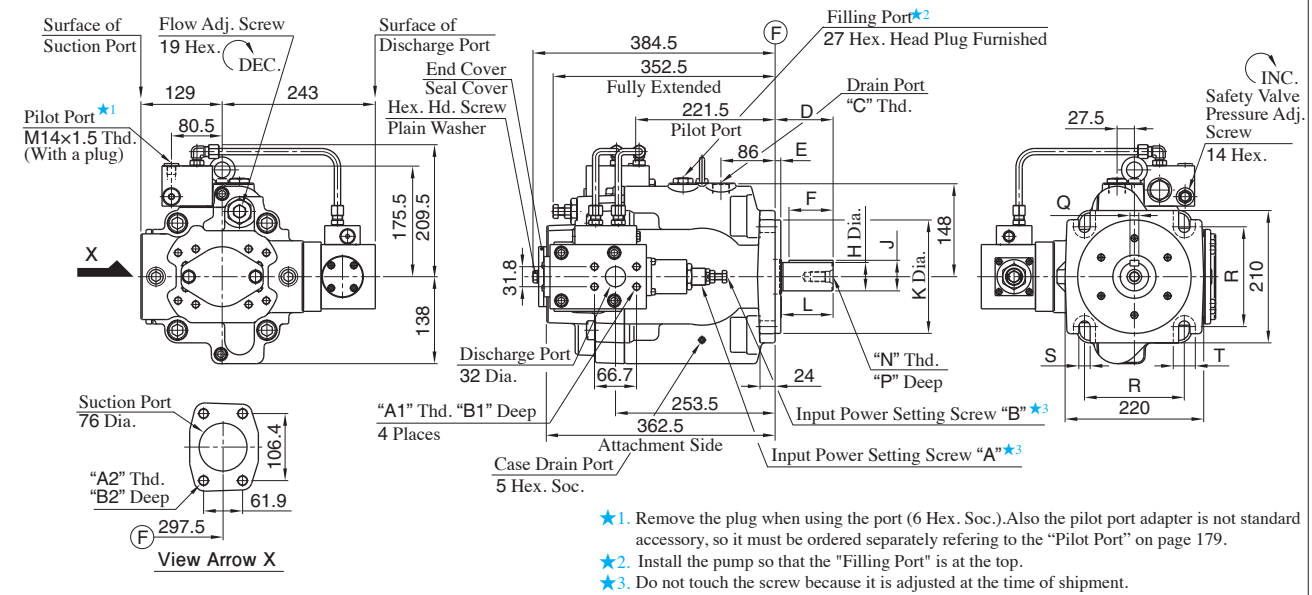

Model Numbers	A1	A2	B1	B2	C	D	E	F	H	J	K	L	N	P	Q	R	S	T	Mounting Flange	Connecting Port	Pipe Flange Threads
A3HG180-FR09V*-K-E1D/E2D	M12	M16	22	29	M27X2	92	9	70	45 ^{+0.018} / _{-0.002}	48.5 ^{+0.018} / _{-0.288}	180 ⁰ / _{-0.063}	82	M16	36	14 ⁰ / _{-0.043}	158.4	18	35	Conforms to ISO 3019-2	Metric	Metric
A3HG180-FR09V*-K-U1D	1/2-13 UNC	5/8-11 UNC	21	29	G 3/4	75	12.7	56	44.45 ⁰ / _{-0.05}	49.39 ⁰ / _{-0.18}	152.4 ⁰ / _{-0.05}	67		32	11.11 ^{+0.03} / ₀	161.6	21.5	39	Conforms to ISO 3019-1	Unified	Unified
A3HG180-FR09V*-K-U2D	M12	M16	22	29	G 3/4	75	12.7	56	44.45 ⁰ / _{-0.05}	49.39 ⁰ / _{-0.18}	152.4 ⁰ / _{-0.05}	67	1/2-13 UNC	32	11.11 ^{+0.03} / ₀	161.6	21.5	39	Conforms to ISO 3019-1	BSPP	Metric
A3HG180-FR09V*-K-J1D	M12	M16	22	29	G 3/4	75	12.7	56	44.45 ⁰ / _{-0.05}	49.39 ⁰ / _{-0.18}	152.4 ⁰ / _{-0.05}	67		32	11.11 ^{+0.03} / ₀	161.6	21.5	39	Conforms to ISO 3019-1	Rc	Metric

Pilot Port

Pilot Port is common to that of "A3HG16-FR07K-E1C/U1C/U2C/J1C"(except the height dimension from the center of the pump). Refer to page 179 for the dimensions of Pilot Port.

Drain Port

Drain Port is common to that of pressure compensator model. Refer to page 174 or 175 for the dimensions of Drain Port.

Foot Mtg.:A3HG145-LR09V*-K-E1D/E2D/U1D/U2D/J1D, A3HG180-LR09V*-K-E1D/E2D/U1D/U2D/J1D

Mounting bracket is common to that of pressure compensator model (except max. height dimension). Refer to page 174 and 175 for the dimensions of mounting bracket.

A3HG Series high Pressure Variable Displacement Piston Pumps Load Sensing Type

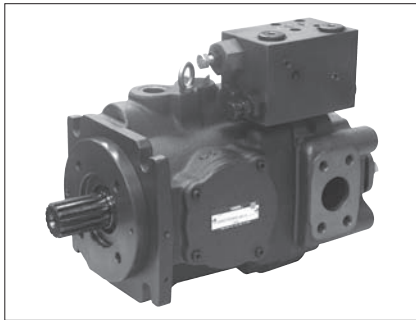

Graphic Symbol

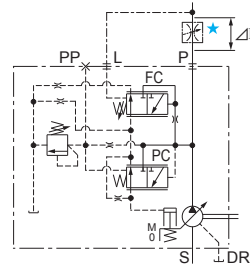

★ A flow control valve is not included with the pump. Install the valve separately.

Specifications

Model Numbers	Geometric Displacement cm ³ /rev	Operating Pressure ^{★1} MPa		Load Sensing Pres. Difference ΔP MPa	Shaft Speed Range r/min		Approx. Mass kg					
		Rated	Intermittent		Max. ^{★3}	Min.	Flange Mtg.	Foot Mtg.				
A3HG16- *R14* - *C-11	16.3	31.5	35	1.5 ^{★2} (At the time of shipment)	3600	600	19.5	23.5				
A3HG37- *R14* - *C-11	37.1				2700	600	29	37.5				
A3HG37- *R14* - *D-11					36.5							
A3HG56- *R14* - *C-11	56.3				2500	600	37	45.5				
A3HG56- *R14* - *D-11					35	42.5						
A3HG71- *R14* -E1D/E2D-11	70.7				2300	600	47.5	73.5				
A3HG71- *R14* -U1D/U2D/J1D-11									44	51.5		
A3HG100- *R14K-E1D/E2D-11	100.5								59	84		
A3HG100- *R14SP* -E1D/E2D-11									2100	600	58.5	83.5
A3HG100- *R14* -U1D/U2D/J1D-11											58.5	85.5
A3HG145- *R14K-E1D/E2D-11									145.2	1800	600	71
A3HG145- *R14SP* -E1D/E2D-11	70.5											96.5
A3HG145- *R14* -U1D/U2D/J1D-11	70.5											98
A3HG180- *R14K-E1D/E2D-11	180.7											1800
A3HG180- *R14SP* -E1D/E2D-11									90	116		
A3HG180- *R14* -U1D/U2D/J1D-11									90	117.5		

- ★1. The operating pressure means pump discharge pressure.
- ★2. Load pressure difference is adjustable in range of 1.0 -3.0 MPa
- ★3. The maximum shaft speeds shown in the above table are at suction pressure 0 kPa.

Model Number Designation

A3HG16	-F	R	14	K	-E1					D	-11
Series Number	Mounting	Direction of Rotation	Control Type	Shaft Extension	Main Pump Mtg. Flange Connecting Port / Pipe Flange Thread Second Pump Mtg.					Number of Pump Mtg. Bolts	Design Number
A3HG16 (16.3 cm ³ /rev)	F: Flange Mtg. L: Foot Mtg.	(Viewed from Shaft End) R: Clockwise (Normal)	14: Load Sensing Type	K: Keyed Shaft SP: Splined Shaft (High torque) SP1: Splined Shaft (Conforms to ISO 3019-1)						C: 2	11
A3HG37 (37.1 cm ³ /rev)										C: 2 D: 4	11
A3HG56 (56.3 cm ³ /rev)											11
A3HG71 (70.7 cm ³ /rev)										D: 4	11
A3HG100 (100.5 cm ³ /rev)											11
A3HG145 (145.2 cm ³ /rev)											11
A3HG180 (180.7 cm ³ /rev)											11

■ Pipe Flange Kits

Pipe flange mouting surface conforms to SAE J 518, 4 bolt split flange.
 Pipe flange kits are not available. Contact us for the details.

Typical Performance Characteristics of Type “A3HG71” at Viscosity 32 mm²/s [ISO VG32 oils, 40°C]

■ Pressure vs. Output Flow

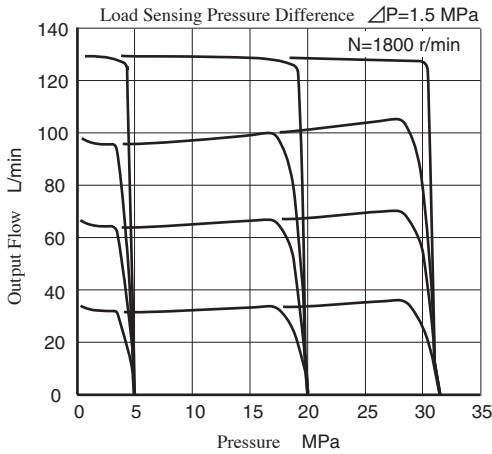

■ Drain

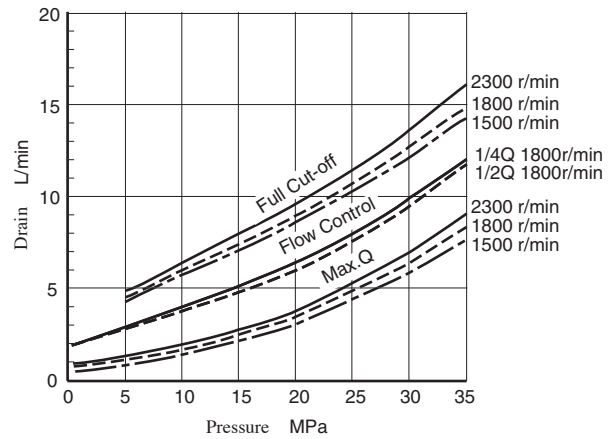

■ Full Cut-off Power

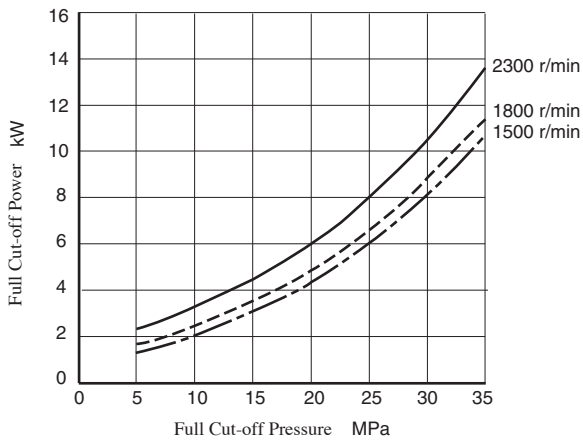

Flange Mtg.:A3HG16-FR14K-E1C/U1C/U2C/J1C

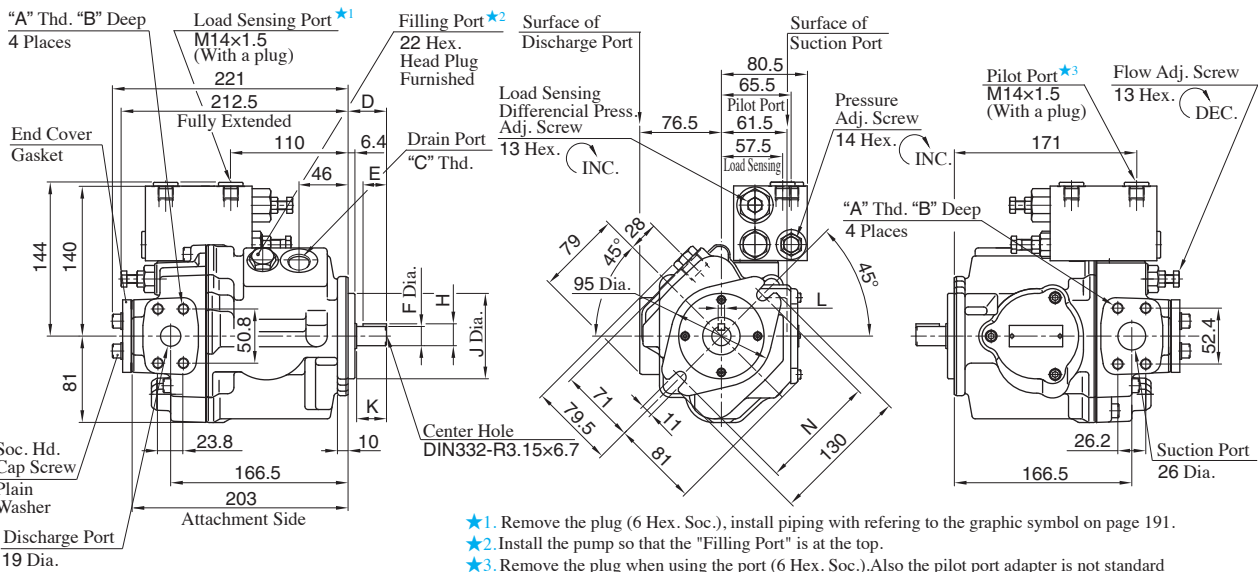

- \star^1 . Remove the plug (6 Hex. Soc.), install piping with referring to the graphic symbol on page 191.
- \star^2 . Install the pump so that the "Filling Port" is at the top.
- \star^3 . Remove the plug when using the port (6 Hex. Soc.). Also the pilot port adapter is not standard accessory, so it must be ordered separately referring to the "Pilot Port" on page 179.

Model Numbers	A	B	C	D	E	F	H	J	K	L	N	Mounting Flange	Connecting Port	Pipe Flange Threads
A3HG16-FR14K-E1C	M10	19	M22x1.5	36	22	18 ^{+0.008} _{-0.003}	20.5 ^{+0.008} _{-0.133}	80 ⁰ _{-0.046}	28	6 ⁰ _{-0.03}	109	Conforms to ISO 3019-2	Metric	Metric
A3HG16-FR14K-U1C	3/8-16 UNC	17	G 1/2	41	28	19.05 ⁰ _{-0.03}	21.24 ⁰ _{-0.16}	82.55 ⁰ _{-0.05}	33	4.76 ^{+0.03} ₀	106	Conforms to ISO 3019-1	Unified	Unified
A3HG16-FR14K-U2C	M10	19	G 1/2	41	28	19.05 ⁰ _{-0.03}	21.24 ⁰ _{-0.16}	82.55 ⁰ _{-0.05}	33	4.76 ^{+0.03} ₀	106	Conforms to ISO 3019-1	BSP	Metric
A3HG16-FR14K-J1C	M10	19	G 1/2	41	28	19.05 ⁰ _{-0.03}	21.24 ⁰ _{-0.16}	82.55 ⁰ _{-0.05}	33	4.76 ^{+0.03} ₀	106	Conforms to ISO 3019-1	Rc	Metric

Load Sensing Port/Pilot Port

Load Sensing Port is common to that of Pilot Port(except the height dimension from the center of the pump). Refer to page 179 for the dimensions of Pilot Port.

Drain Port

Drain Port is common to that of pressure compensator model.Refer to page 167 for the dimensions of Drain Port.

Foot Mtg.:A3HG16-LR14K-E1C/U1C/U2C/J1C

Mounting bracket is common to that of pressure compensator model (except max height dimension). Refer to page 167 for the dimensions of mounting bracket.

Flange Mtg. Two Bolts:A3HG37-FR14K-E1C/E2C/U1C/U2C/J1C

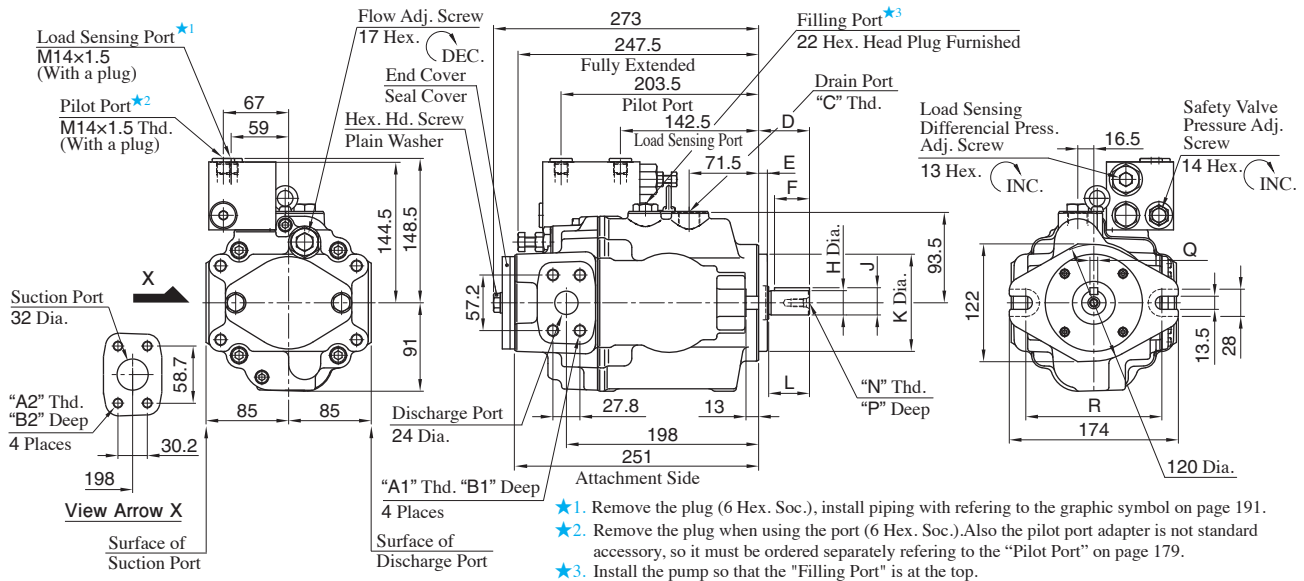

- ★1. Remove the plug (6 Hex. Soc.), install piping with referring to the graphic symbol on page 191.
- ★2. Remove the plug when using the port (6 Hex. Soc.).Also the pilot port adapter is not standard accessory, so it must be ordered separately referring to the "Pilot Port" on page 179.
- ★3. Install the pump so that the "Filling Port" is at the top.

Model Numbers	A1	A2	B1	B2	C	D	E	F	H	J	K	L	N	P	Q	R	Mounting Flange	Connecting Port	Pipe Flange Threads
A3HG37-FR14K-E1C/E2C	M12	M10	22	18	M22X1.5	52	9	36	25 ^{+0.009} _{-0.004}	28 ^{+0.009} _{-0.294}	100 ⁰ _{0.054}	42	M8	19	8 ⁰ _{-0.036}	140	Conforms to ISO 3019-2	Metric	Metric
A3HG37-FR14K-U1C	7/16-14 UNC		20		G 1/2	46	9.7	32	25.4 ⁰ _{-0.05}	28.18 ⁰ _{0.18}	101.6 ⁰ _{0.05}	38	1/4	16	6.35 ^{+0.03} ₀	146	Conforms to ISO 3019-1	Unified	Unified
A3HG37-FR14K-U2C	M12	M10	22	18	G 1/2	46	9.7	32	25.4 ⁰ _{-0.05}	28.18 ⁰ _{0.18}	101.6 ⁰ _{0.05}	38	20 UNC	16	6.35 ^{+0.03} ₀	146	Conforms to ISO 3019-1	BSP	Metric
A3HG37-FR14K-J1C	M12	M10	22	18	G 1/2	46	9.7	32	25.4 ⁰ _{-0.05}	28.18 ⁰ _{0.18}	101.6 ⁰ _{0.05}	38	16	6.35 ^{+0.03} ₀	146	Conforms to ISO 3019-1	Rc	Metric	

Flange Mtg. Four Bolts:A3HG37-FR14K-E1D/E2D/U1D/U2D/J1D

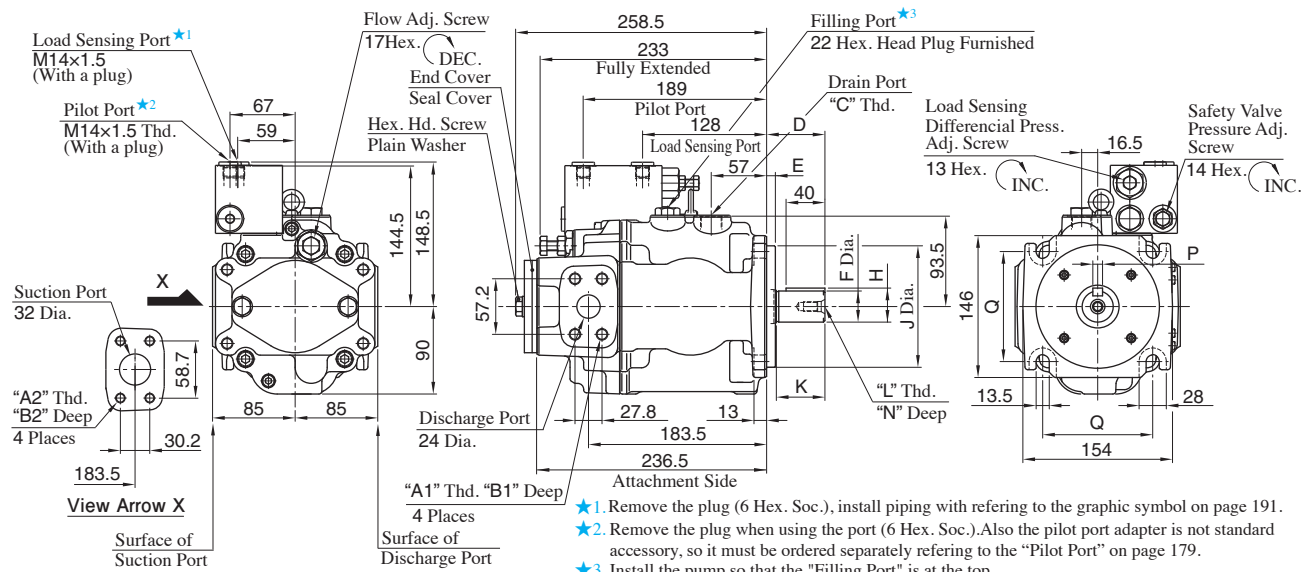

- ★1. Remove the plug (6 Hex. Soc.), install piping with referring to the graphic symbol on page 191.
- ★2. Remove the plug when using the port (6 Hex. Soc.).Also the pilot port adapter is not standard accessory, so it must be ordered separately referring to the "Pilot Port" on page 179.
- ★3. Install the pump so that the "Filling Port" is at the top.

Model Numbers	A1	A2	B1	B2	C	D	E	F	H	J	K	L	N	P	Q	Mounting Flange	Connecting Port	Pipe Flange Threads
A3HG37-FR14K-E1D/E2D	M12	M10	22	18	M22X1.5	60	9	32 ^{+0.018} _{+0.002}	35 ^{+0.018} _{-0.288}	125 ⁰ _{-0.063}	50	M10	22	10 ⁰ _{-0.036}	113.2	Conforms to ISO 3019-2	Metric	Metric
A3HG37-FR14K-U1D	7/16-14 UNC		20		G 1/2	56	12.7	31.75 ⁰ _{-0.05}	35.32 ⁰ _{-0.18}	127 ⁰ _{-0.05}	48	5/16-18 UNC	19	7.94 ^{+0.03} ₀	114.5	Conforms to ISO 3019-1	Unified	Unified
A3HG37-FR14K-U2D	M12	M10	22	18	G 1/2	56	12.7	31.75 ⁰ _{-0.05}	35.32 ⁰ _{-0.18}	127 ⁰ _{-0.05}	48	5/16-18 UNC	19	7.94 ^{+0.03} ₀	114.5	Conforms to ISO 3019-1	BSP	Metric
A3HG37-FR14K-J1D	M12	M10	22	18	G 1/2	56	12.7	31.75 ⁰ _{-0.05}	35.32 ⁰ _{-0.18}	127 ⁰ _{-0.05}	48	19	7.94 ^{+0.03} ₀	114.5	Conforms to ISO 3019-1	Rc	Metric	

Load Sensing Port/Pilot Port

Load Sensing Port is common to that of Pilot Port(except the height dimension from the center of the pump). Refer to page 179 for the dimensions of Pilot Port.

Drain Port

Drain Port is common to that of pressure compensator model.Refer to page 168 or 169 for the dimensions of Drain Port.

Foot Mtg.:A3HG37-LR14K-E1C/E2C/U1C/U2C/J1C, A3HG37-LR14K-E1D/E2D/U1D/U2D/J1D

Mounting bracket is common to that of pressure compensator model (except max height dimension). Refer to page 168 and 169 for the dimensions of mounting bracket.

Flange Mtg. Two Bolts:A3HG56-FR14K-E1C/E2C/U1C/U2C/J1C

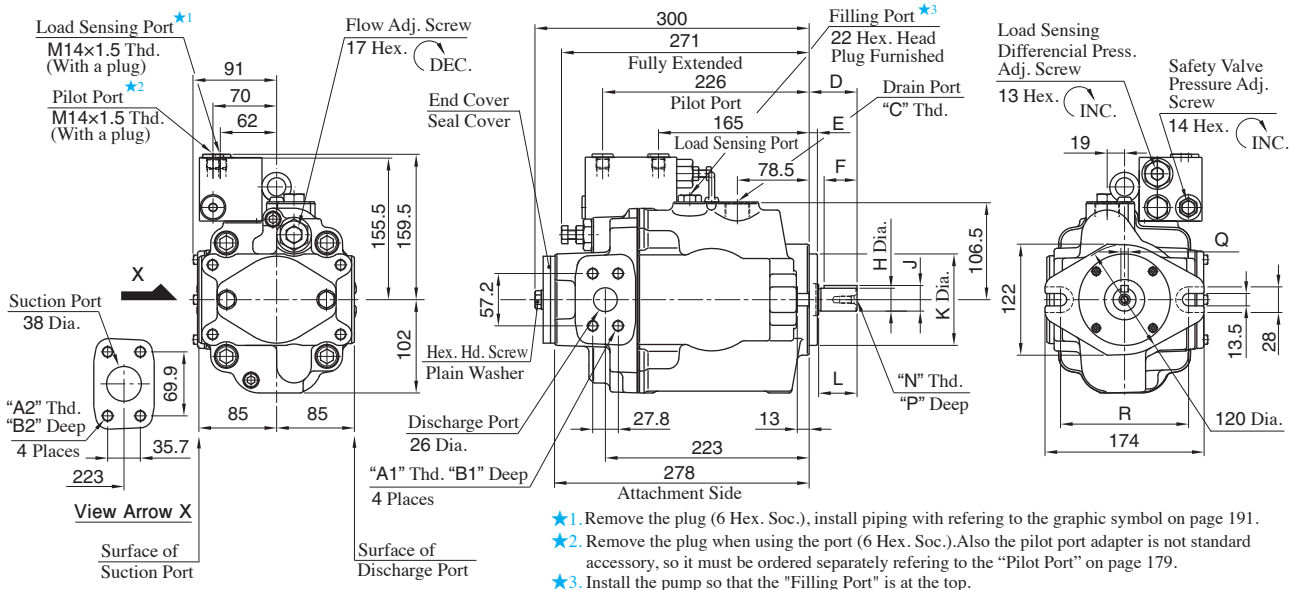

Model Numbers	A1	A2	B1	B2	C	D	E	F	H	J	K	L	N	P	Q	R	Mounting Flange	Connecting Port	Pipe Flange Threads
A3HG56-FR14K-E1C/E2C	M12	M12	22	22	M27X2	52	9	36	25 ^{+0.009} _{-0.004}	28 ^{+0.009} _{-0.294}	100 ⁰ _{0.054}	42	M8	19	8 ⁰ _{-0.036}	140	Conforms to ISO 3019-2	Metric	Metric
A3HG56-FR14K-U1C	7/16-14 UNC	1/2-13 UNC	20	21	G 3/4	46	9.7	32	25.4 ⁰ _{-0.05}	28.18 ⁰ _{-0.18}	101.6 ⁰ _{-0.05}	38	1/4-20 UNC	16	6.35 ^{+0.03} ₀	146	Conforms to ISO 3019-1	Unified	Unified
A3HG56-FR14K-U2C	M12	M12	22	22	G 3/4	46	9.7	32	25.4 ⁰ _{-0.05}	28.18 ⁰ _{-0.18}	101.6 ⁰ _{-0.05}	38	1/4-20 UNC	16	6.35 ^{+0.03} ₀	146	Conforms to ISO 3019-1	BSPP	Metric
A3HG56-FR14K-J1C	M12	M12	22	22	G 3/4	46	9.7	32	25.4 ⁰ _{-0.05}	28.18 ⁰ _{-0.18}	101.6 ⁰ _{-0.05}	38	16	6.35 ^{+0.03} ₀	146	Conforms to ISO 3019-1	Rc	Metric	

Flange Mtg. Four Bolts:A3HG56-FR14K-E1D/E2D/U1D/U2D/J1D

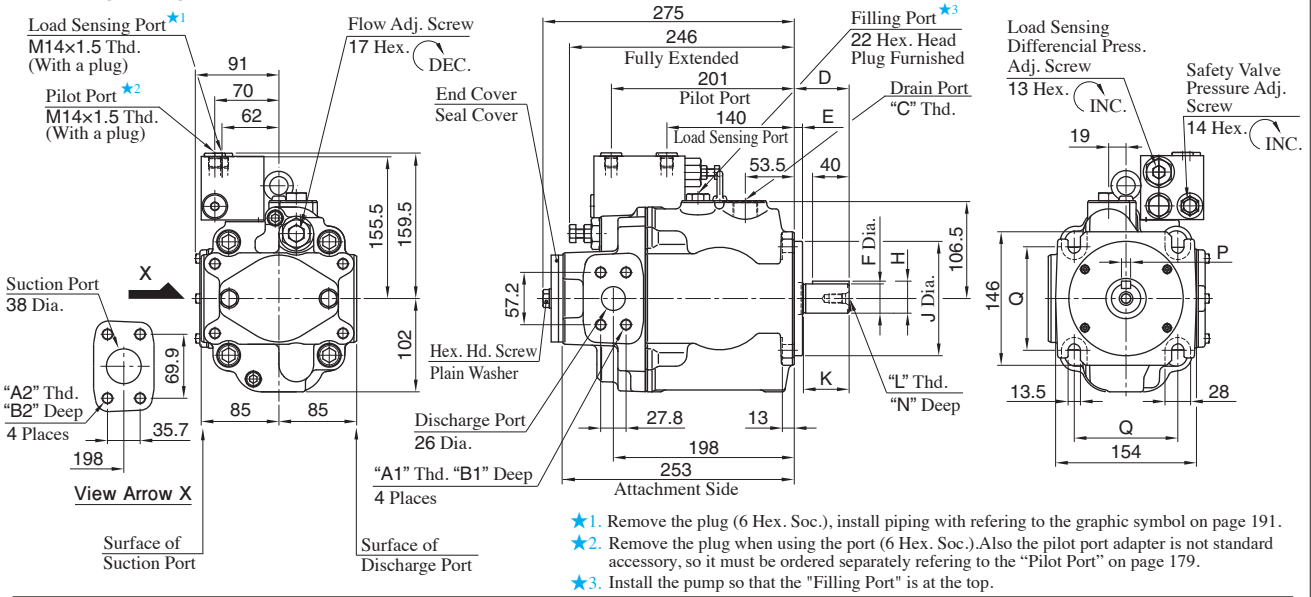

Model Numbers	A1	A2	B1	B2	C	D	E	F	H	J	K	L	N	P	Q	R	Mounting Flange	Connecting Port	Pipe Flange Threads
A3HG56-FR14K-E1D/E2D	M12	M12	22	22	M27X2	60	9	32 ^{+0.018} _{+0.002}	35 ^{+0.018} _{-0.288}	125 ⁰ _{-0.063}	50	M10	22	10 ⁰ _{-0.036}	113.2	Conforms to ISO 3019-2	Metric	Metric	
A3HG56-FR14K-U1D	7/16-14 UNC	1/2-13 UNC	20	21	G 3/4	56	12.7	31.75 ⁰ _{-0.05}	35.32 ⁰ _{-0.18}	127 ⁰ _{-0.05}	48	5/16-18 UNC	19	7.94 ^{+0.03} ₀	114.5	Conforms to ISO 3019-1	Unified	Unified	
A3HG56-FR14K-U2D	M12	M12	22	22	G 3/4	56	12.7	31.75 ⁰ _{-0.05}	35.32 ⁰ _{-0.18}	127 ⁰ _{-0.05}	48	5/16-18 UNC	19	7.94 ^{+0.03} ₀	114.5	Conforms to ISO 3019-1	BSPP	Metric	
A3HG56-FR14K-J1D	M12	M12	22	22	G 3/4	56	12.7	31.75 ⁰ _{-0.05}	35.32 ⁰ _{-0.18}	127 ⁰ _{-0.05}	48	19	7.94 ^{+0.03} ₀	114.5	Conforms to ISO 3019-1	Rc	Metric		

Load Sensing Port/Pilot Port

Load Sensing Port is common to that of Pilot Port(except the height dimension from the center of the pump). Refer to page 179 for the dimensions of Pilot Port.

Drain Port

Drain Port is common to that of pressure compensator model.Refer to page 170 or 171 for the dimensions of Drain Port.

Foot Mtg.:A3HG56-LR14K-E1C/E2C/U1C/U2C/J1C, A3HG56-LR14K-E1D/E2D/U1D/U2D/J1D

Mounting bracket is common to that of pressure compensator model (except max height dimension). Refer to page 170 and 171 for the dimensions of mounting bracket.

Flange Mtg.:A3HG71-FR14K-E1D/E2D/U1D/U2D/J1D

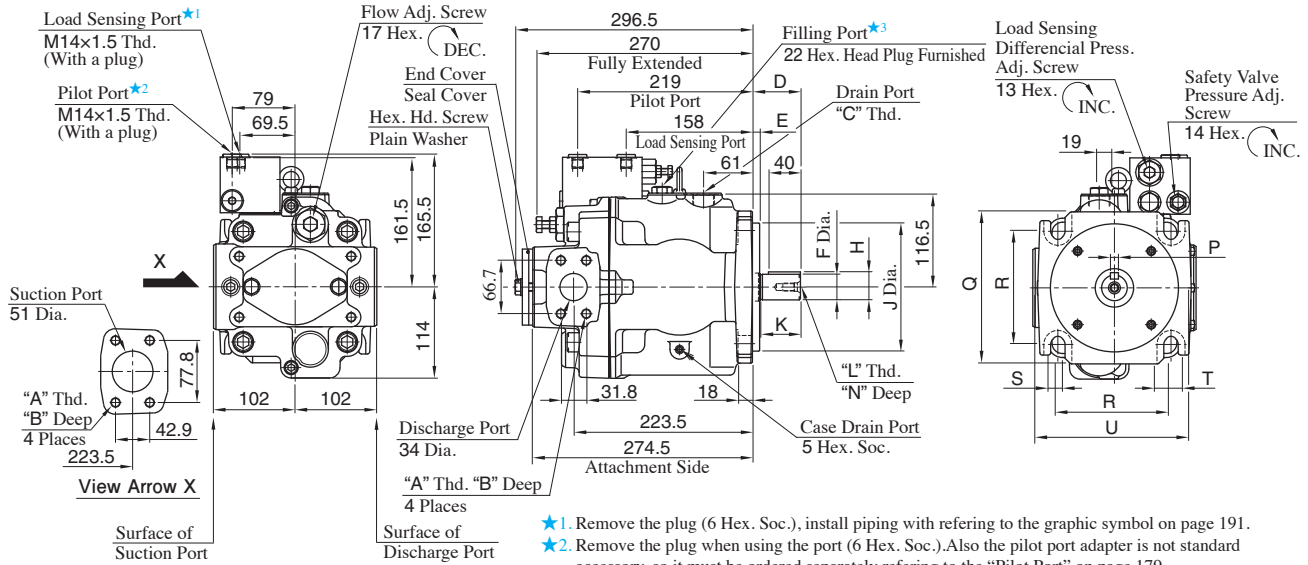

- ★1. Remove the plug (6 Hex. Soc.), install piping with referring to the graphic symbol on page 191.
- ★2. Remove the plug when using the port (6 Hex. Soc.).Also the pilot port adapter is not standard accessory, so it must be ordered separately referring to the "Pilot Port" on page 179.
- ★3. Install the pump so that the "Filling Port" is at the top.

Model Numbers	A	B	C	D	E	F	H	J	K	L	N	P	Q	R	S	T	U	Mounting Flange	Connecting Port	Pipe Flange Threads
A3HG71-FR14K-E1D/E2D	M12	22	M27×2	60	9	32 ^{+0.018} _{+0.002}	35 ^{+0.018} _{-0.288}	160 ⁰ _{-0.063}	50	M10	22	10 ⁰ _{-0.036}	190	141.4	18	35	192	Conforms to ISO 3019-2	Metric	Metric
A3HG71-FR14K-U1D	1/2-13 UNC	21	G 3/4	56	12.7	31.75 ⁰ _{-0.05}	35.32 ⁰ _{-0.18}	127 ⁰ _{-0.05}	48		19	7.94 ^{+0.03} ₀	143	114.5	13.5	28	155	Conforms to ISO 3019-1	Unified	Unified
A3HG71-FR14K-U2D	M12	22	G 3/4	56	12.7	31.75 ⁰ _{-0.05}	35.32 ⁰ _{-0.18}	127 ⁰ _{-0.05}	48	5/16-18 UNC	19	7.94 ^{+0.03} ₀	143	114.5	13.5	28	155	Conforms to ISO 3019-1	BSP	Metric
A3HG71-FR14K-J1D	M12	22	G 3/4	56	12.7	31.75 ⁰ _{-0.05}	35.32 ⁰ _{-0.18}	127 ⁰ _{-0.05}	48		19	7.94 ^{+0.03} ₀	143	114.5	13.5	28	155	Conforms to ISO 3019-1	Rc	Metric

Flange Mtg.:A3HG100-FR14K-E1D/E2D/U1D/U2D/J1D

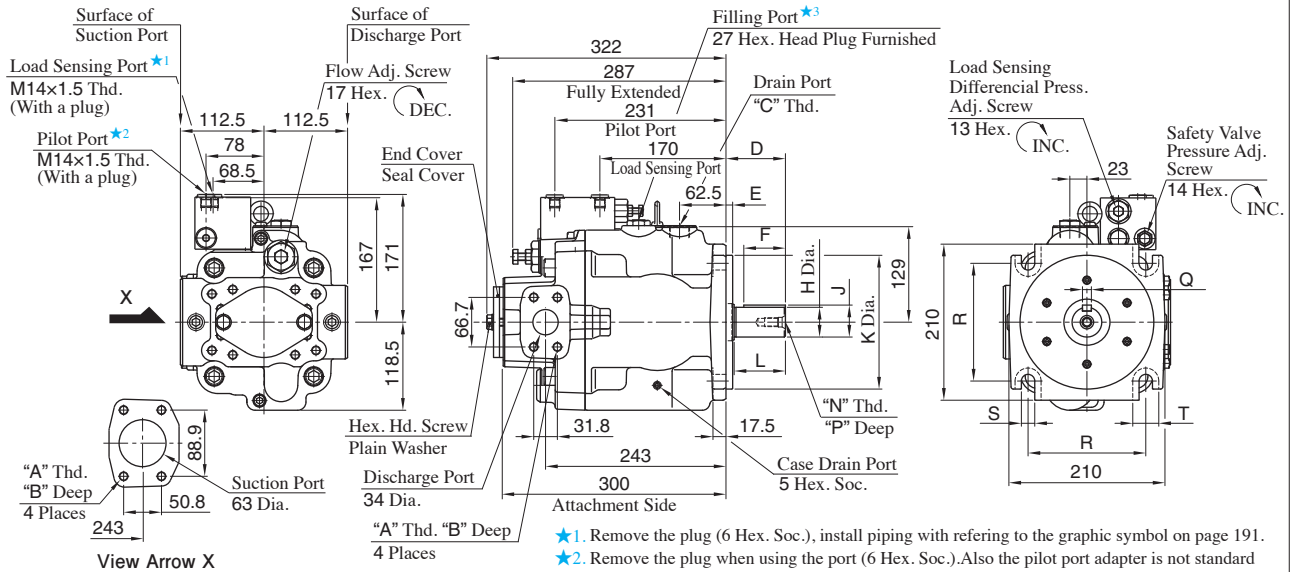

- ★1. Remove the plug (6 Hex. Soc.), install piping with referring to the graphic symbol on page 191.
- ★2. Remove the plug when using the port (6 Hex. Soc.).Also the pilot port adapter is not standard accessory, so it must be ordered separately referring to the "Pilot Port" on page 179.
- ★3. Install the pump so that the "Filling Port" is at the top.

Model Numbers	A	B	C	D	E	F	H	J	K	L	N	P	Q	R	S	T	U	Mounting Flange	Connecting Port	Pipe Flange Threads
A3HG100-FR14K-E1D/E2D	M12	22	M27×2	80	9	40 ^{+0.018} _{+0.002}	43 ^{+0.018} _{-0.288}	180 ⁰ _{-0.063}	70	M12	28	12 ⁰ _{-0.043}	158.4	18	35			Conforms to ISO 3019-2	Metric	Metric
A3HG100-FR14K-U1D	1/2-13 UNC	21	G 3/4	62	12.7	38.1 ⁰ _{-0.05}	42.36 ⁰ _{-0.18}	152.4 ⁰ _{-0.05}	54		28	9.53 ^{+0.03} ₀	161.6	21.5	39			Conforms to ISO 3019-1	Unified	Unified
A3HG100-FR14K-U2D	M12	22	G 3/4	62	12.7	38.1 ⁰ _{-0.05}	42.36 ⁰ _{-0.18}	152.4 ⁰ _{-0.05}	54	7/16-14 UNC	28	9.53 ^{+0.03} ₀	161.6	21.5	39			Conforms to ISO 3019-1	BSP	Metric
A3HG100-FR14K-J1D	M12	22	G 3/4	62	12.7	38.1 ⁰ _{-0.05}	42.36 ⁰ _{-0.18}	152.4 ⁰ _{-0.05}	54		28	9.53 ^{+0.03} ₀	161.6	21.5	39			Conforms to ISO 3019-1	Rc	Metric

Load Sensing Port/Pilot Port

Load Sensing Port is common to that of Pilot Port(except the height dimension from the center of the pump). Refer to page 179 for the dimensions of Pilot Port.

Drain Port

Drain Port is common to that of pressure compensator model.Refer to page 172 or 173 for the dimensions of Drain Port.

Foot Mtg.:A3HG71-LR14K-E1D/E2D/U1D/U2D/J1D, A3HG100-LR14K-E1D/E2D/U1D/U2D/J1D

Mounting bracket is common to that of pressure compensator model (except max height dimension). Refer to page 172 and 173 for the dimensions of mounting bracket.

Mounting Interchangeability between Old and New Models

Load sensing type A3HG series piston pumps were remodeled to enhance the reliability of the products.

Major Changes

Control valves were changed.

Design Number

Design Number 10 → Design Number 11

Mounting Interchangeability

Not interchangeable

The mounting positions for a load sensing port and a pilot port are changed. See the following page for details.

Performance (example : A3HG71)

Name	Old Model	New Model
Pressure vs. Output Flow		
Drain		

Dimensions

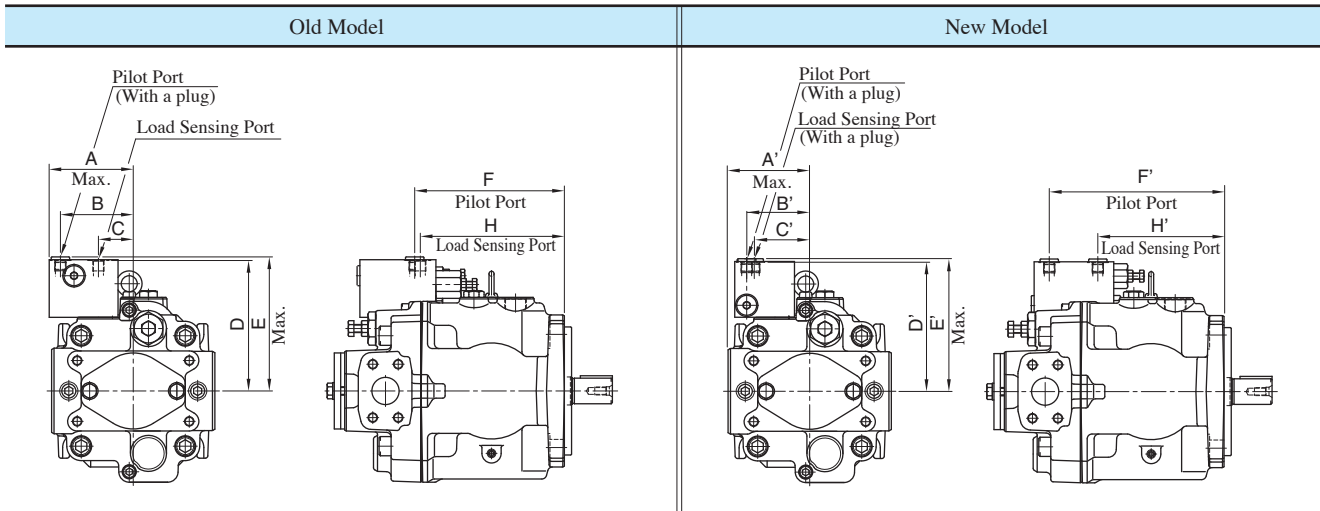

Old Model								New Model							
Model Number	A	B	C	D	E	F	H	Model Number	A'	B'	C'	D'	E'	F'	H'
A3HG16-*R14*-*C-10	89.5	75.5	31.5	142	146	138.5	131.5	A3HG16-*R14*-*C-11	80.5	65.5	57.5	140	144	171	110
A3HG37-*R14*-*C-10	91	77	33	146.5	150.5	171	164	A3HG37-*R14*-*C-11	85	67	59	144.5	148.5	203.5	142.5
A3HG37-*R14*-*D-10	91	77	33	146.5	150.5	156.5	149.5	A3HG37-*R14*-*D-11	85	67	59	144.5	148.5	189	128
A3HG56-*R14*-*C-10	94	80	36	157.5	161.5	193.5	186.5	A3HG56-*R14*-*C-11	91	70	62	155.5	159.5	226	165
A3HG56-*R14*-*D-10	94	80	36	157.5	161.5	168.5	161.5	A3HG56-*R14*-*D-11	91	70	62	155.5	159.5	201	140
A3HG71-*R14*-*D-10	105	91	43.5	163.5	167.5	187	180	A3HG71-*R14*-*D-11	102	79	69.5	161.5	165.5	219	158
A3HG100-*R14*-*D-10	112.5	90	42.5	169	173	199	192	A3HG100-*R14*-*D-11	112.5	78	68.5	167	171	231	170
A3HG145-*R14*-*D-10	123	93.5	46	175.5	179.5	222.5	215.5	A3HG145-*R14*-*D-11	123	81.5	72	173.5	177.5	254.5	193.5
A3HG180-*R14*-*D-10	129	87.5	40	183.5	190	249.5	242.5	A3HG180-*R14*-*D-11	129	75.5	66	181.5	190	281.5	220.5

Graphic Symbol

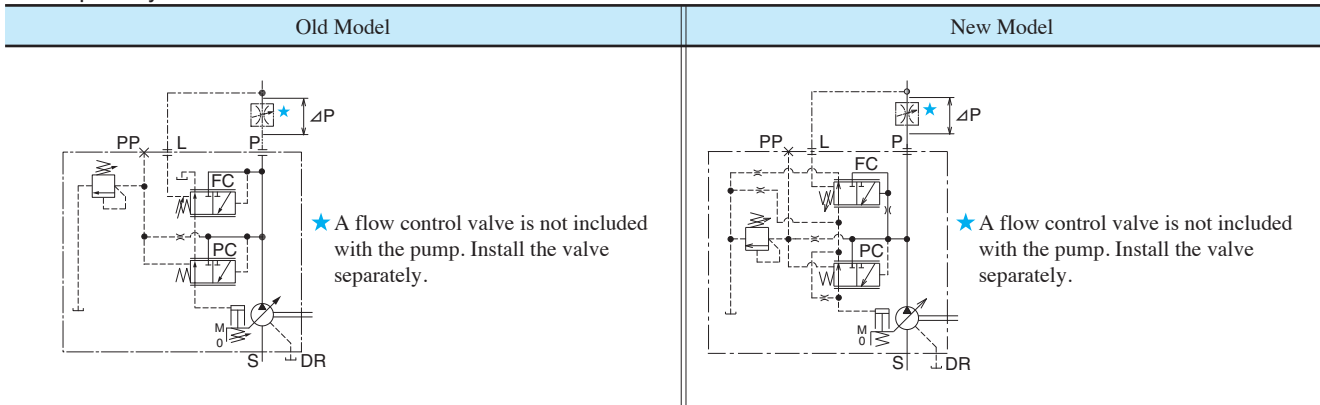

Splined Shaft End

● Flange Mtg.:A3HG *-FR**SP

● Flange Mtg.:A3HG *-FR**SP1

● Foot Mtg.:A3HG *-LR**KSP*

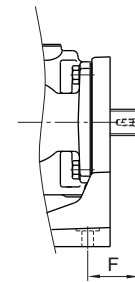
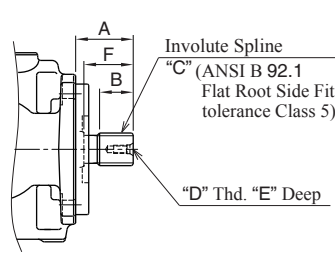
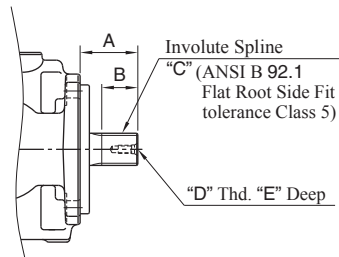

Model Numbers	A	B	C	D	E	F*
A3HG16-FR**SP-*C	38	19.5	11T-16/32DP	1/4-20 UNC	14	—
A3HG16-FR**SP1-*C	38	17.8	11T-16/32DP	1/4-20 UNC	14	30
A3HG37-FR**SP-*C	46	25	15T-16/32DP	1/4-20 UNC	16	—
A3HG37-FR**SP1-*C	46	23.2	15T-16/32DP	1/4-20 UNC	16	38
A3HG37-FR**SP-*D	56	35	14T-12/24DP	5/16-18 UNC	19	—
A3HG37-FR**SP1-*D	56	32.7	14T-12/24DP	5/16-18 UNC	19	48
A3HG56-FR**SP-*C	46	25	15T-16/32DP	1/4-20 UNC	16	—
A3HG56-FR**SP1-*C	46	23.2	15T-16/32DP	1/4-20 UNC	16	38
A3HG56-FR**SP-*D	56	35	14T-12/24DP	5/16-18 UNC	19	—
A3HG56-FR**SP1-*D	56	32.7	14T-12/24DP	5/16-18 UNC	19	48
A3HG71-FR**SP-*D	56	35	14T-12/24DP	5/16-18 UNC	19	—
A3HG71-FR**SP1-*D	56	32.7	14T-12/24DP	5/16-18 UNC	19	48
A3HG100-FR**SP-*D	62	38	17T-12/24DP	7/16-14 UNC	28	—
A3HG100-FR**SP1-*D	62	35.7	17T-12/24DP	7/16-14 UNC	28	54
A3HG145-FR**SP-*D	75	45	13T-8/16DP	1/2-13 UNC	32	—
A3HG145-FR**SP1-*D	75	41.7	13T-8/16DP	1/2-13 UNC	32	67
A3HG180-FR**SP-*D	75	45	13T-8/16DP	1/2-13 UNC	32	—
A3HG180-FR**SP1-*D	75	41.7	13T-8/16DP	1/2-13 UNC	32	67

*Frang/Port code:U1C/U2C/J1C or U1D/U2D/J1D

Model Numbers	F
A3HG16-LR**SP*-*C	35
A3HG37-LR**SP*-*C	38
A3HG37-LR**SP*-*D	61
A3HG56-LR**SP*-*C	38
A3HG56-LR**SP*-*D	61
A3HG71-LR**SP*-*E1D	69
A3HG71-LR**SP*-*U1D/U2D/J1D	61
A3HG100-LR**SP*-*D	75
A3HG145-LR**SP*-*D	28
A3HG180-LR**SP*-*D	28

● For other dimensions, refer to "Flange Mtg.".

Second Pump

The through drive system allows a main pump to be used as a double pump with a connected second pump.

● Connecting pump

1. Remove the End Cover and Seal Cover
2. Insert the O-Ring, which is the attachment of seal cover, to the second pump of spigot joint part of boss.
3. Prepare the coupling and adapter (Flange) separately and joint the second pump.

For the ISO 3019-1 pump mount flange, through drive kits with components required to connect a second pump, such as couplings and adapters (flanges), are available. For more details, refer to page ●●●.

● Allowable Input Torque

The maximum torque of pumps is limited by shaft and coupling assembly strength. When determining the second pump type, the value of the torque for a particular pump should not exceed the value shown in the table below.

Model Numbers	Number of Pump Mtg. Bolts	(1)Allowable Input Torque T ₁ +T ₂ Nm	(2)Second pump input torque T ₂ Nm	
A3HG16-*R*KK-E1C	two	94 or less	87 or less	
A3HG16-*R*KK-U1C/U2C/J1C		135 or less		
A3HG16-*R*KSP*-*C		136 or less		
A3HG37/56-*R*KK-E1C/E2C	two	279 or less	—	
A3HG37-*R*KK-U1C/U2C/J1C		263 or less		
A3HG56-*R*KK-U1C/U2C/J1C		364 or less		
A3HG37/56-*R*KSP*-*C	four	451 or less	297 or less	
A3HG37/56/71-*R*KK-E1D/E2D		528 or less		
A3HG37-*R*KK-U1D/U2D/J1D				801 or less
A3HG56-*R*KK-U1D/U2D/J1D				
A3HG71-*R*KK-U1D/U2D/J1D		789 or less		
A3HG37/56/71-*R*KSP-*D				
A3HG37/56/71-*R*KSP1-*D		609 or less		
A3HG100-*R*KK-E1D/E2D	four		1965 or less	
A3HG100-*R*KK-U1D/U2D/J1D				1321 or less
A3HG100-*R*KSP-*D		1196 or less		
A3HG100-*R*KSP1-*D				1295 or less
A3HG145/180-*R*KK-E1D/E2D	four	609 or less		
A3HG145-*R*KK-U1D/U2D/J1D			1436 or less	
A3HG180-*R*KK-U1D/U2D/J1D				1965 or less
A3HG145/180-*R*KSP-*D			1686 or less	
A3HG145/180-*R*KSP1-*D				

★1. T₁: Main pump input torque
T₂: Second pump input torque
Torque Formula

$$T = \frac{P \times q}{2\pi} \quad T: \text{Input Torque [Nm]} \quad P: \text{Pressure [MPa]} \quad q: \text{Displacement [cm}^3/\text{rev]}$$

★2. For selection of the appropriate pump, both values, (1) and (2), should be satisfied.

A3HG16

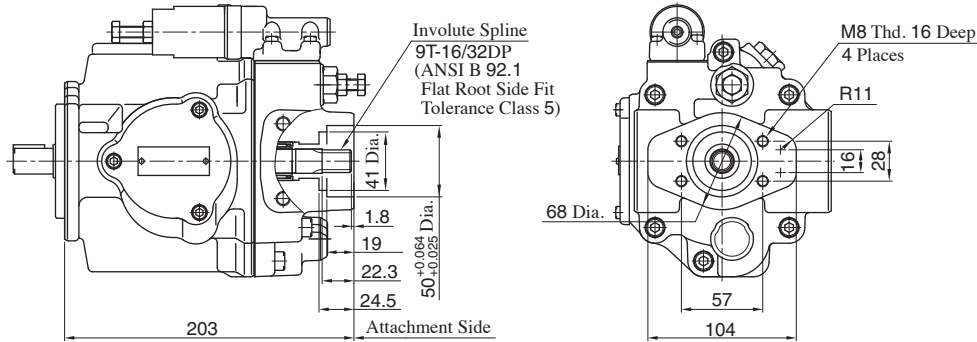

A3HG37/A3HG56

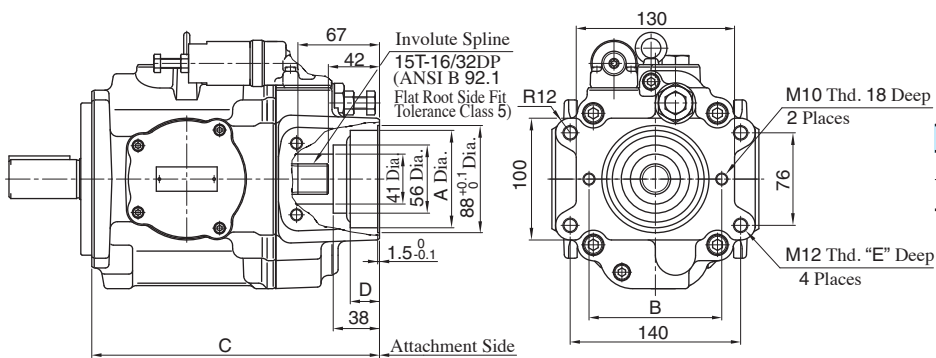

Frang/Port Code	A	B
E1	80 ^{+0.076} Dia. _{+0.030}	109
E2/U1/U2/J1	82.55 ^{+0.090} Dia. _{+0.036}	106

Model Number	C	D	E
A3HG37-*R***-*C	251	24	22
A3HG37-*R***-*D	236.5		
A3HG56-*R***-*C	278	28	19
A3HG56-*R***-*D	253		

A3HG71

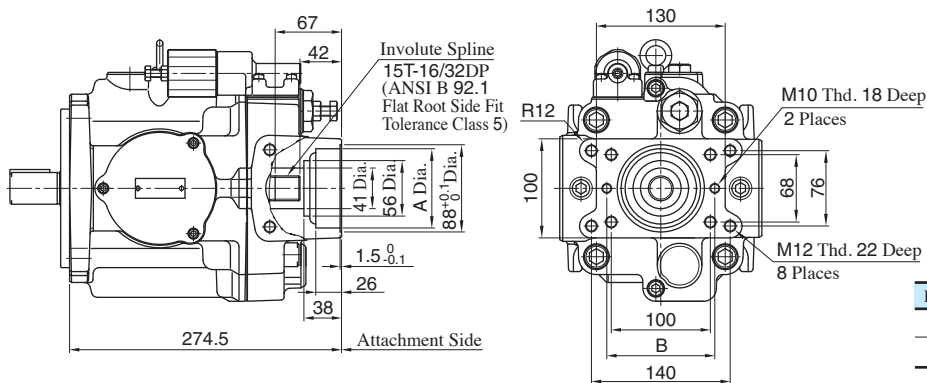

Frang/Port Code	A	B
E1	80 ^{+0.076} Dia. _{+0.030}	109
E2/U1/U2/J1	82.55 ^{+0.090} Dia. _{+0.036}	106

A3HG100/A3HG145/A3HG180

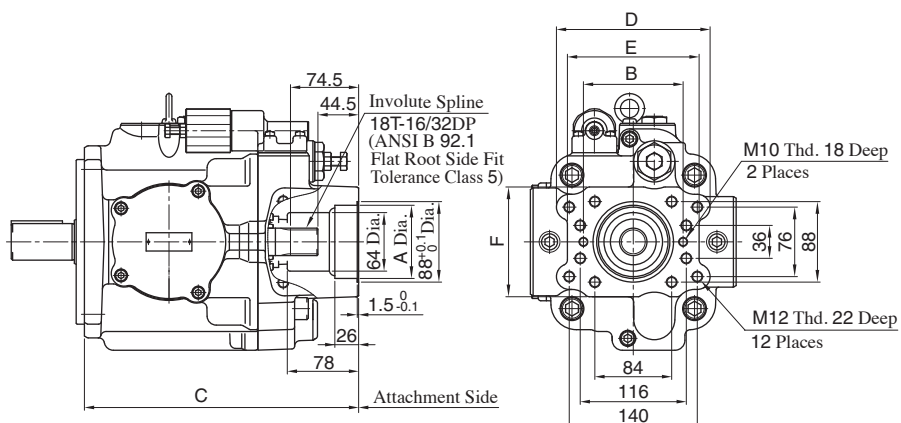

Frang/Port Code	A	B
E1	80 ^{+0.076} Dia. _{+0.030}	109
E2/U1/U2/J1	82.55 ^{+0.090} Dia. _{+0.036}	106

Series Number	C	D	E	F
A3HG100	300	168	144	120
A3HG145	323.5	174	146	120
A3HG180	362.5	174	146	146

Through Drive Kit

Pump Mount Flange

Main Pump and Second Pump Frange/Port Code	Pump Mount Flange
E2/U1/U2/J1	ISO 3019-1

Pump Combination

● Key Type

Main Pump *	A3HG16	A3HG37	A3HG56	A3HG71	A3HG100	A3HG145	A3HG180
Second Pump							
A3HG16-***K-E2C/U1C/U2C/J1C	TG1-A-A2-ABK		TG1-B-A2-ABK			TG1-C-A2-ABK	
A3HG37-***K-E2C/U1C/U2C/J1C			TG1-B-B2-BBK			TG1-C-B2-BBK	
A3HG37-***K-E2D/U1D/U2D/J1D			TG1-B-C4-CK			TG1-C-C4-CK	
A3HG56-***K-E2C/U1C/U2C/J1C			TG1-B-B2-BBK			TG1-C-B2-BBK	
A3HG56-***K-E2D/U1D/U2D/J1D			TG1-B-C4-CK			TG1-C-C4-CK	
A3HG71-***K-E2D/U1D/U2D/J1D				TG1-B-C4-CK		TG1-C-C4-CK	
A3HG100-***K-E2D/U1D/U2D/J1D						TG1-C-D4-CCK	
A3HG145-***K-E2D/U1D/U2D/J1D						TG1-C-D4-DK	
A3HG180-***K-E2D/U1D/U2D/J1D							TG1-C-D4-DK

★ Frange/Port Code:E2/U1/U2/J1

● Spline Type

Main Pump *	A3HG16	A3HG37	A3HG56	A3HG71	A3HG100	A3HG145	A3HG180
Second Pump							
A3HG16-***SP*E2C/U1C/U2C/J1C	TG1-A-A2-ABSP		TG1-B-A2-ABSP			TG1-C-A2-ABSP	
A3HG37-***SP*E2C/U1C/U2C/J1C			TG1-B-B2-BBSP			TG1-C-B2-BBSP	
A3HG37-***SP*E2D/U1D/U2D/J1D			TG1-B-C4-CSP			TG1-C-C4-CSP	
A3HG56-***SP*E2C/U1C/U2C/J1C			TG1-B-B2-BBSP			TG1-C-B2-BBSP	
A3HG56-***SP*E2D/U1D/U2D/J1D			TG1-B-C4-CSP			TG1-C-C4-CSP	
A3HG71-***SP*E2D/U1D/U2D/J1D				TG1-B-C4-CSP		TG1-C-C4-CSP	
A3HG100-***SP*E2D/U1D/U2D/J1D						TG1-C-D4-CCSP	
A3HG145-***SP*E2D/U1D/U2D/J1D						TG1-C-D4-DSP	
A3HG180-***SP*E2D/U1D/U2D/J1D							TG1-C-D4-DSP

★ Frange/Port Code:E2/DU1/U2/J1

Model Number Designation

TG1	-A	-A	2	-AB	K	-10
Series Number	Main Pump	Second Pump Mtg. Flange ISO Code (ISO 3019-1)	Second Pump Number of Mtg. Bolts	Second Pump Shaft End ISO Code(ISO 3019-1)	Second Pump Shaft Extension	Design Number
TG1	A:A3HG16	A: 82	2:Two	AB: 19	K: Keyed Shaft	10
	B: A3HG37- A3HG71	A: 82	2:Two	AB: 19		
		B: 101	2:Two	BB: 25		
	C: A3HG100- A3HG180	C: 127	4:Four	C: 32	SP: Splined Shaft	
		A: 82	2:Two	AB: 19		
		B: 101	2:Two	BB: 25		
		C: 127	4:Four	C: 32		
	D: 152	4:Four	CC: 38			
			D: 44			

Connecting pump

● Key Type

TG1-A-A2-ABK

- Mount the gasket and flange to the main pump, and fix it with hexagon socket head cap screws.
Tightening torque : 30.9 - 37.7 Nm
- Insert the coupling into the shaft end of the second pump, position the coupling at a point where it reaches the shaft end, as shown in the figure below, and then fix the coupling with hexagon socket set screws.
Tightening torque : 1.50 - 1.84 Nm
- Apply lithium grease to the O-ring, and insert the O-ring into the male spigot of the second pump (see the figure right).
- Prepare M10 hexagon head bolts (hardness classification: 10.9) and plain washers (hardness classification: 22H Hv 220-300).
Mount the second pump to the flange with the bolts and washers.

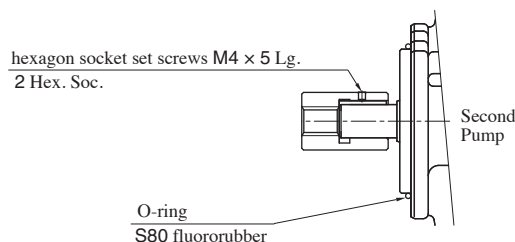

TG1-B-A2-ABK, TG1-C-A2-ABK

- (1) Mount the coupling to the shaft end of the second pump, position the coupling at a point where the coupling shaft end reaches the stepped portion of the second pump shaft, as shown in the figure below, and then fix the coupling with hexagon socket set screws.
Tightening torque : 1.50 - 1.84 Nm
- (2) Apply lithium grease to the S80 O-ring, and insert the O-ring into the male spigot of the flange.
- (3) Prepare M10 hexagon head bolts (hardness classification: 10.9) and plain washers (hardness classification: 22H Hv 220-300).
Mount the second pump to main pump with the bolts and washers.

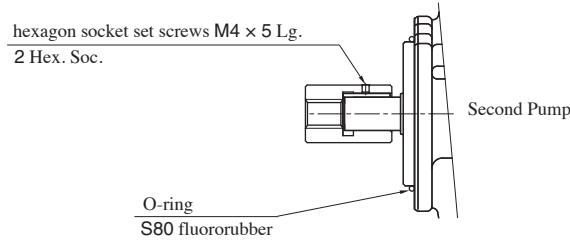

TG1-B-B2-BBK, TG1-B-C4-CK, TG1-C-B2-BBK, TG1-C-C4-CK

- (1) Apply lithium grease to the S80 O-ring, and insert the O-ring into the male spigot of the flange. Mount the flange to the main pump with hexagon socket head cap screws.
Tightening torque : 104 - 127 Nm
- (2) Insert the coupling into the shaft end of the second pump, position the coupling at a point where it reaches the shaft end, as shown in the figure below, and then fix the coupling with hexagon socket set screws.
Tightening torque : 5.31 - 6.49 Nm
- (3) Apply lithium grease to the O-ring, and insert the O-ring into the male spigot of the second pump (see the figure below).
- (4) Prepare M12 hexagon head bolts (hardness classification: 10.9) and plain washers (hardness classification: 22H Hv 220-300).
Mount the second pump to the flange with the bolts and washers.

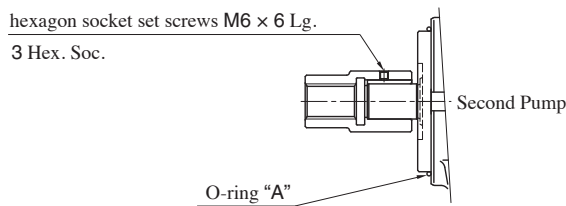

Model Numbers	O-ring "A"
TG1-B-B2-BBK	S100 fluororubber
TG1-C-B2-BBK	
TG1-B-C4-CK	S125 fluororubber
TG1-C-C4-CK	

TG1-C-D4-CCK, TG1-C-D4-DK

- (1) Mount the P16 O-ring to the O-ring groove on the reverse side of the flange (see the figure below).
- (2) Apply lithium grease to the S80 O-ring, and insert the O-ring into the male spigot of the flange. Mount the flange to the main pump with hexagon socket head cap screws.
Tightening torque : 104 - 127 Nm
- (3) Insert the coupling into the shaft end of the second pump, position the coupling at a point where it reaches the shaft end, as shown in the figure below, and then fix the coupling with hexagon socket set screws.
Tightening torque : 5.31 - 6.49 Nm
- (4) Apply lithium grease to the G160 O-ring, and mount the O-ring to the O-ring groove on the flange.
- (5) Prepare M20 hexagon head bolts (hardness classification: 10.9) and plain washers (hardness classification: 22H Hv 220-300).
Mount the second pump to the flange with the bolts and washers.

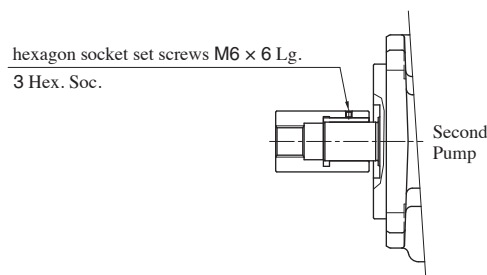
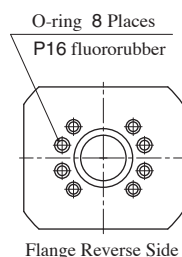

● Spline Type

TG1-A-A2-ABSP

- (1) Mount the gasket and flange to the main pump, and fix it with hexagon socket head cap screws.
Tightening torque : 30.9 - 37.7 Nm
- (2) Mount the coupling to the shaft end of the second pump or the main pump.
- (3) Apply lithium grease to the S80 O-ring, and insert the O-ring into the male spigot of the second pump (see the figure below).
- (4) Prepare M10 hexagon head bolts (hardness classification: 10.9) and plain washers (hardness classification: 22H Hv 220-300).
Mount the second pump to the flange with the bolts and washers.

TG1-B-A2-ABSP, TG1-C-A2-ABSP

- (1) Mount the coupling to the shaft end of the second pump or the main pump.
- (2) Apply lithium grease to the S80 O-ring, and insert the O-ring into the male spigot of the second pump (see the figure below).
- (3) Prepare M10 hexagon head bolts (hardness classification: 10.9) and plain washers (hardness classification: 22H Hv 220-300).
Mount the second pump to the main pump with the bolts and washers.

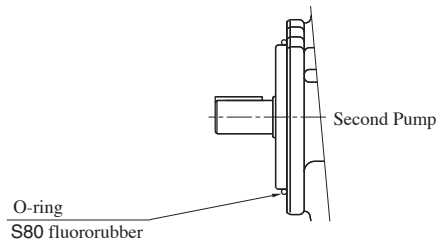

TG1-B-B2-BBSP, TG1-B-C4-CSP, TG1-C-B2-BBSP, TG1-C-C4-CSP

- (1) Apply lithium grease to the S80 O-ring, and insert the O-ring into the male spigot of the flange. Mount the flange to the main pump with hexagon socket head cap screws.
Tightening torque : 104 - 127 Nm
- (2) Mount the coupling to the shaft end of the second pump or the main pump.
- (3) Apply lithium grease to the O-ring, and insert the O-ring into the male spigot of the second pump (see the figure below).
- (4) Prepare M12 hexagon head bolts (hardness classification: 10.9) and plain washers (hardness classification: 22H Hv 220-300).
Mount the second pump to the flange with the bolts and washers.

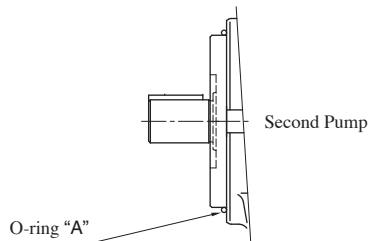

Model Numbers	O-ring "A"
TG1-B-B2-BBSP	S100 fluororubber
TG1-C-B2-BBSP	
TG1-B-C4-CSP	S125 fluororubber
TG1-C-C4-CSP	

TG1-C-D4-CCSP, TG1-C-D4-DSP

- (1) Mount the P16 O-ring to the O-ring groove on the reverse side of the flange (see the figure below).
- (2) Apply lithium grease to the S80 O-ring, and insert the O-ring into the male spigot of the flange. Mount the flange to the main pump with hexagon socket head cap screws.
Tightening torque : 104 - 127 Nm
- (3) Mount the coupling to the shaft end of the second pump or the main pump.
- (4) Apply lithium grease to the G160 O-ring, and mount the O-ring to the O-ring groove on the flange.
- (5) Prepare M20 hexagon head bolts (hardness classification: 10.9) and plain washers (hardness classification: 22H Hv 220-300).
Mount the second pump to the flange with the bolts and washers.

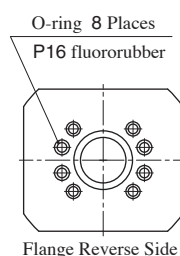

TG1-A-A2-ABK

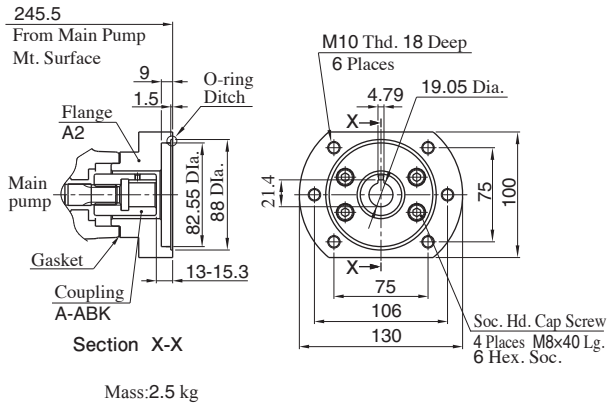

TG1-A-A2-ABSP

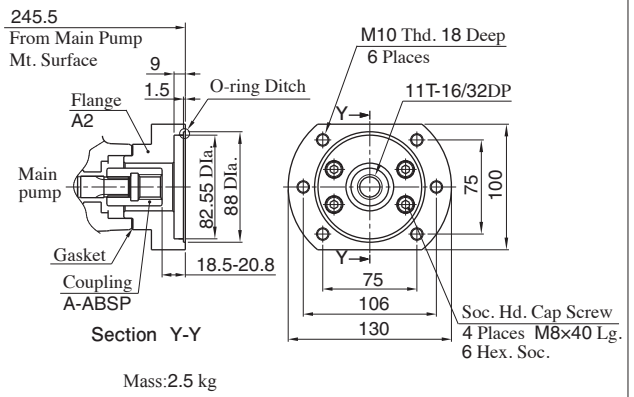

TG1-B-A2-ABK/TG1-C-A2-ABK

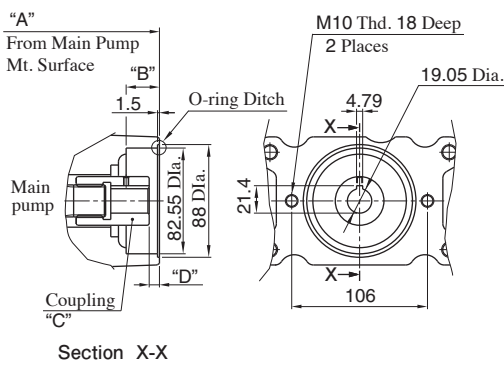

TG1-B-A2-ABSP/TG1-C-A2-ABSP

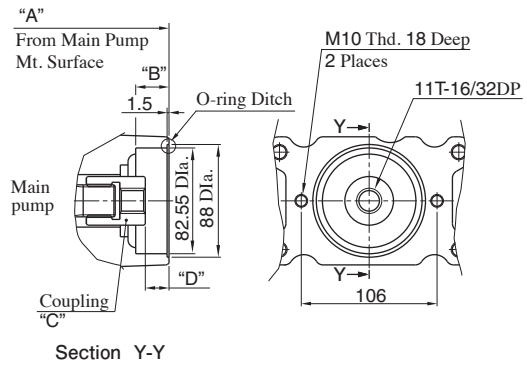

Through Drive Kit	Main Pump	A	B	C	D	Mass kg
TG1-B-A2-ABK	A3HG37-*R**K-E2C/U1C/U2C/J1C	251	24	B-ABK	8-10	0.3
	A3HG37-*R**K-E2D/U1D/U2D/J1D	236.5				
	A3HG56-*R**K-E2C/U1C/U2C/J1C	278				
	A3HG56-*R**K-E2D/U1D/U2D/J1D	253				
	A3HG71-*R**K-E2D/U1D/U2D/J1D	274.5				
TG1-C-A2-ABK	A3HG100-*R**K-E2D/U1D/U2D/J1D	300	26	C-ABK	8-11.5	0.4
	A3HG145-*R**K-E2D/U1D/U2D/J1D	323.5				
	A3HG180-*R**K-E2D/U1D/U2D/J1D	362.5				

Through Drive Kit	Main Pump	A	B	C	D	Mass kg
TG1-B-A2-ABSP	A3HG37-*R**SP*-E2C/U1C/U2C/J1C	251	24	B-ABSP	18.5-21	0.3
	A3HG37-*R**SP*-E2D/U1D/U2D/J1D	236.5				
	A3HG56-*R**SP*-E2C/U1C/U2C/J1C	278				
	A3HG56-*R**SP*-E2D/U1D/U2D/J1D	253				
	A3HG71-*R**SP*-E2D/U1D/U2D/J1D	274.5				
TG1-C-A2-ABSP	A3HG100-*R**SP*-E2D/U1D/U2D/J1D	300	26	C-ABSP	18.5-20.5	0.4
	A3HG145-*R**SP*-E2D/U1D/U2D/J1D	323.5				
	A3HG180-*R**SP*-E2D/U1D/U2D/J1D	362.5				

TG1-B-B2-BBK/TG1-C-B2-BBK

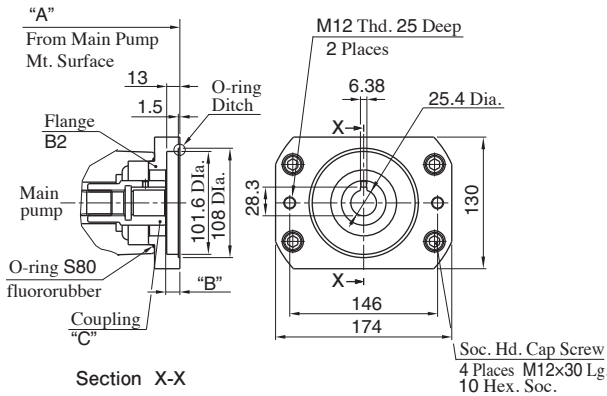

TG1-B-B2-BBSP/TG1-C-B2-BBSP

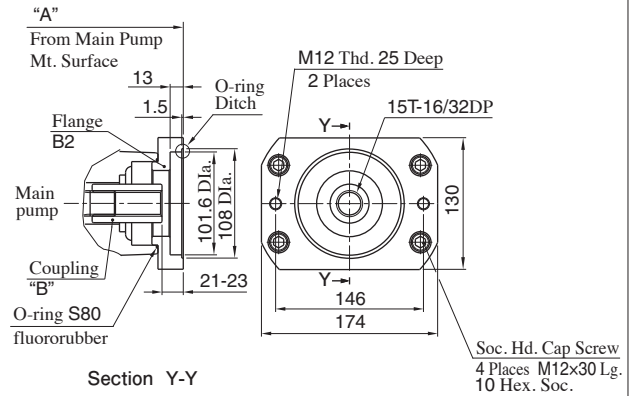

Through Drive Kit	Main Pump	A	B	C	Mass kg
TG1-B-B2-BBK	A3HG37-*R**K-E2C/U1C/U2C/J1C	276	14-15	B-BBK	3.6
	A3HG37-*R**K-E2D/U1D/U2D/J1D	261.5			
	A3HG56-*R**K-E2C/U1C/U2C/J1C	303			
	A3HG56-*R**K-E2D/U1D/U2D/J1D	278			
	A3HG71-*R**K-E2D/U1D/U2D/J1D	299.5			
TG1-C-B2-BBK	A3HG100-*R**K-E2D/U1D/U2D/J1D	325	14-16.5	C-BBK	3.7
	A3HG145-*R**K-E2D/U1D/U2D/J1D	348.5			
	A3HG180-*R**K-E2D/U1D/U2D/J1D	387.5			

Through Drive Kit	Main Pump	A	B	Mass kg
TG1-B-B2-BBSP	A3HG37-*R**SP*-E2C/U1C/U2C/J1C	276	B-BBSP	3.5
	A3HG37-*R**SP*-E2D/U1D/U2D/J1D	261.5		
	A3HG56-*R**SP*-E2C/U1C/U2C/J1C	303		
	A3HG56-*R**SP*-E2D/U1D/U2D/J1D	278		
	A3HG71-*R**SP*-E2D/U1D/U2D/J1D	299.5		
TG1-C-B2-BBSP	A3HG100-*R**SP*-E2D/U1D/U2D/J1D	325	C-BBSP	3.5
	A3HG145-*R**SP*-E2D/U1D/U2D/J1D	348.5		
	A3HG180-*R**SP*-E2D/U1D/U2D/J1D	387.5		

TG1-B-C4-CK/TG1-C-C4-CK

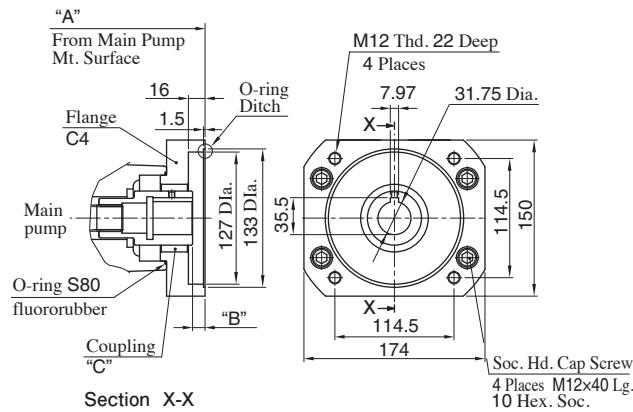

Through Drive Kit	Main Pump	A	B	C	Mass kg
TG1-B-C4-CK	A3HG37-*R**K-E2C/U1C/U2C/J1C	288	12-14	B-CK	5.8
	A3HG37-*R**K-E2D/U1D/U2D/J1D	273.5			
	A3HG56-*R**K-E2C/U1C/U2C/J1C	315			
	A3HG56-*R**K-E2D/U1D/U2D/J1D	290			
	A3HG71-*R**K-E2D/U1D/U2D/J1D	311.5			
TG1-C-C4-CK	A3HG100-*R**K-E2D/U1D/U2D/J1D	337	12-14.5	C-CK	6
	A3HG145-*R**K-E2D/U1D/U2D/J1D	360.5			
	A3HG180-*R**K-E2D/U1D/U2D/J1D	399.5			

TG1-B-C4-CSP/TG1-C-C4-CSP

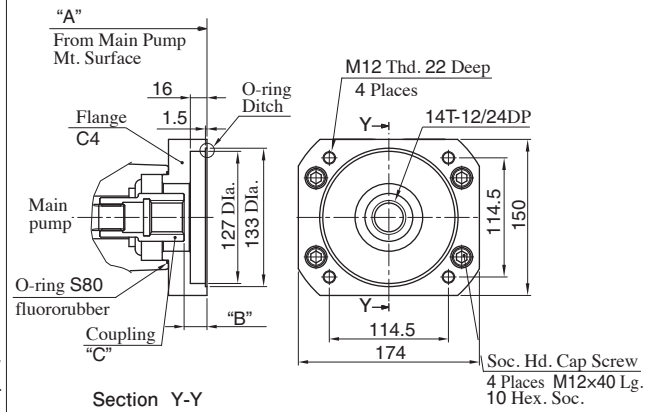

Through Drive Kit	Main Pump	A	B	C	Mass kg
TG1-B-C4-CSP	A3HG37-*R**SP*-E2C/U1C/U2C/J1C	288	21-23	B-CSP	5.6
	A3HG37-*R**SP*-E2D/U1D/U2D/J1D	273.5			
	A3HG56-*R**SP*-E2C/U1C/U2C/J1C	315			
	A3HG56-*R**SP*-E2D/U1D/U2D/J1D	290			
	A3HG71-*R**SP*-E2D/U1D/U2D/J1D	311.5			
TG1-C-C4-CSP	A3HG100-*R**SP*-E2D/U1D/U2D/J1D	337	21-23.5	C-CSP	5.7
	A3HG145-*R**SP*-E2D/U1D/U2D/J1D	360.5			
	A3HG180-*R**SP*-E2D/U1D/U2D/J1D	399.5			

TG1-C-D4-CCK/TG1-C-D4-DK

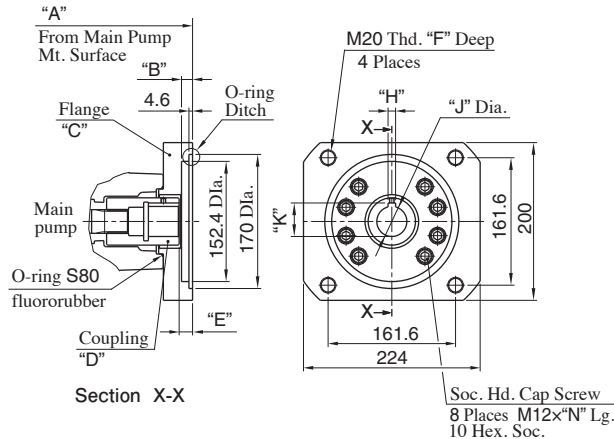

Through Drive Kit	Main Pump	A	B	C
TG1-C-D4-CCK	A3HG100-*R**K-E2D/U1D/U2D/J1D	337	14	D4-1
	A3HG145-*R**K-E2D/U1D/U2D/J1D	360.5		
	A3HG180-*R**K-E2D/U1D/U2D/J1D	399.5		
TG1-C-D4-DK	A3HG145-*R**K-E2D/U1D/U2D/J1D	383.5	15	D4-2
	A3HG180-*R**K-E2D/U1D/U2D/J1D	422.5		

Through Drive Kit	D	E	F	H	J	K	N	Mass kg
TG1-C-D4-CCK	C-CCK	17-19.5	37	9.56	38.1	42.5	30	10.7
TG1-C-D4-DK	C-DK	19-21.5	34	11.14	44.45	49.6	50	16.7

TG1-C-D4-CCSP/TG1-C-D4-DSP

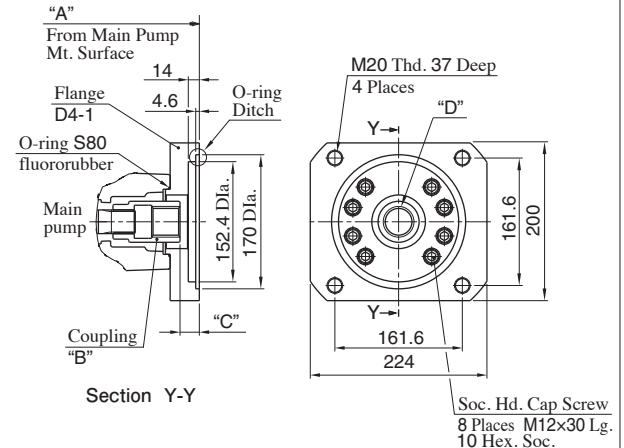

Through Drive Kit	Main Pump	A	B	C
TG1-C-D4-CCSP	A3HG100-*R**SP*-E2D/U1D/U2D/J1D	337	C-CCSP	24-26.5
	A3HG145-*R**SP*-E2D/U1D/U2D/J1D	360.5		
	A3HG180-*R**SP*-E2D/U1D/U2D/J1D	399.5		
TG1-C-D4-DSP	A3HG145-*R**SP*-E2D/U1D/U2D/J1D	360.5	C-DSP	30-32.5
	A3HG180-*R**SP*-E2D/U1D/U2D/J1D	399.5		

Through Drive Kit	D	Mass kg
TG1-C-D4-CCSP	17T-12/24DP	10
TG1-C-D4-DSP	13T-8/16DP	10.2